

# Performance Test of GSO -bar (E949)

Yoichi Tamagawa

(Fukui-Univ.)

tama@midori.apphy.fukui-u.ac.jp

1. GSO ?

2. Experimental Setup

3. Result

4. Conclusion

stacking

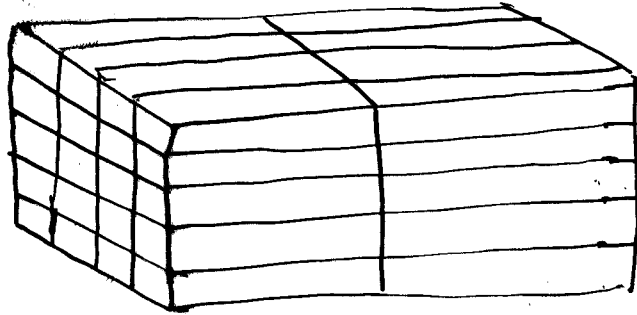

with other scint.

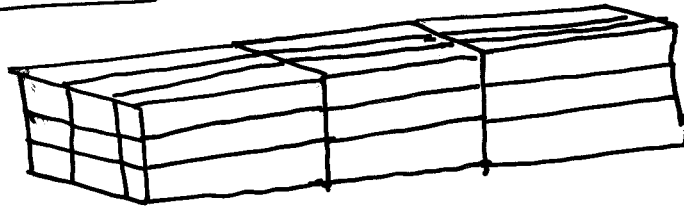

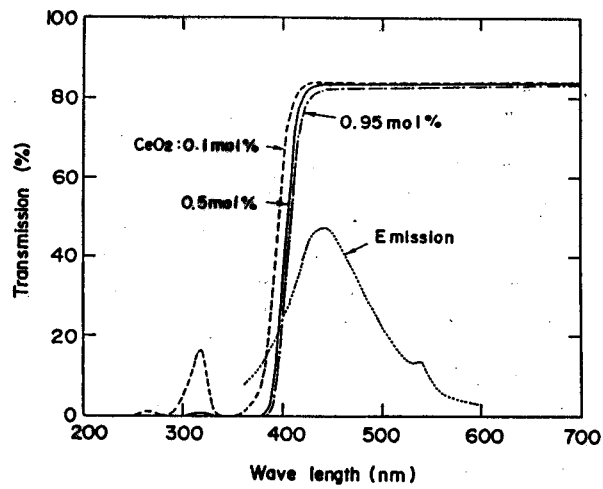

Table 4. Characteristics of typical scintillators for nuclear and high energy physics applications.

Quantity	<u>NaI:Tl</u>	CsI:Tl	Bi <sub>4</sub> Ge <sub>3</sub> O <sub>12</sub>	<u>Gd<sub>2</sub>SiO<sub>5</sub>:Ce</u>	CsI	BaF <sub>2</sub>
<u>Density</u> (g/cm <sup>3</sup> )	3.67	4.53	7.13	<u>6.71</u>	4.53	4.89
<u>Radiation length</u> X <sub>0</sub> (cm)	2.59	1.86	1.12	<u>1.38</u>	1.86	2.03
<u>Decay constant</u> (ns)	230	1050	300	<u>30-60</u>	10/1000	0.6/620
<u>Peak emission</u> (nm)	415	550	480	<u>440</u>	305/>400	220/310
<u>Light yield</u> (relative)	100	85	7-10	<u>20</u>	~4/~1	5/16
<u>Index of refraction</u> <sup>+</sup>	1.85	1.80	2.15	<u>1.85</u>	1.8	1.56
<u>Peak excitation</u> (nm)	290	300	280	<u>310, 350</u>	---	---
<u>Hygroscopicity</u>	strong	slight	no	<u>no</u>	slight	no
<u>Melting point</u> (°C)	651	621	1050	<u>1900</u>	621	1354
<u>Radiation hardness</u> (rad)	10 <sup>a</sup>	10 <sup>a</sup>	10 <sup>4-5</sup>	<u>&gt;10<sup>a</sup></u>	10 <sup>4-5</sup>	10 <sup>6-7</sup>
<u>Hardness</u> (Mohs)	2	2	5	<u>5.7</u>	2	3
<u>Cleavage</u>	(100)	none	none	<u>(100)</u>	none	(111)
<u>available length</u> <sup>+</sup> (X <sub>0</sub> )	>20	>20	>20	<u>13</u>	>20	10-15
<u>price</u> <sup>+</sup> (\$/cc)	1-2	2	10-12	<u>20-25</u>	2	3-6

+ ) at the wavelength of the peak emission.

\* ) only approximate numbers.

progress IN CRYSTAL GROWTH ..

M. Kobayashi. 1982

# GSO Crystals

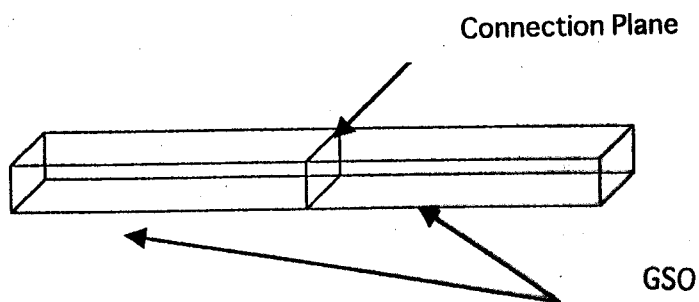
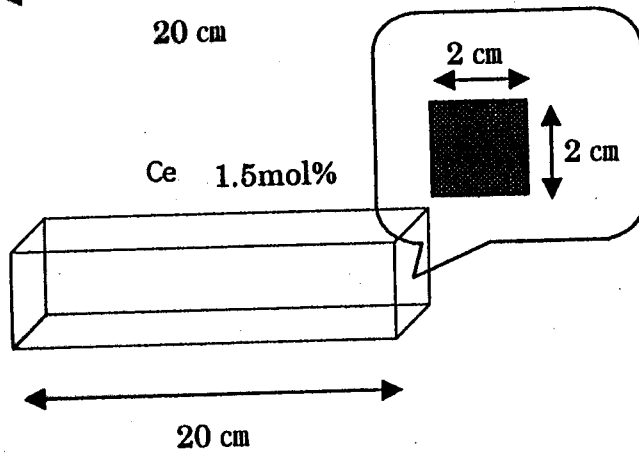
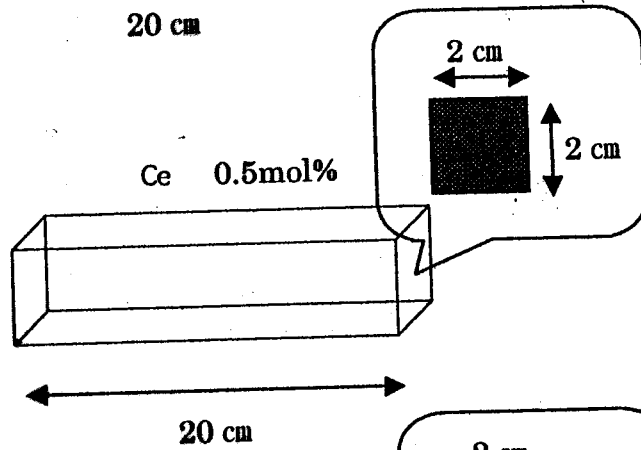
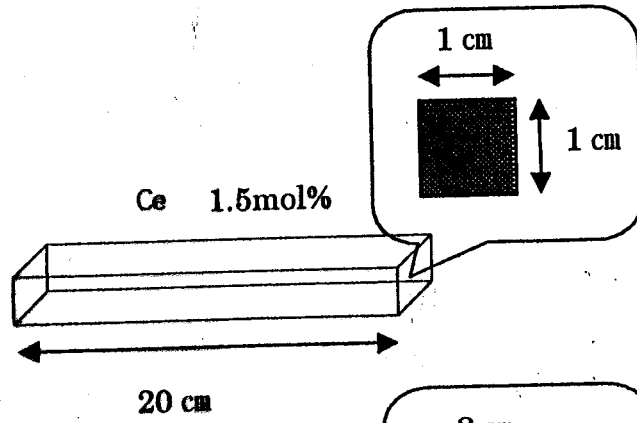

KEK. PS. T1

0.6  
0.8 GeV/c  
1.0

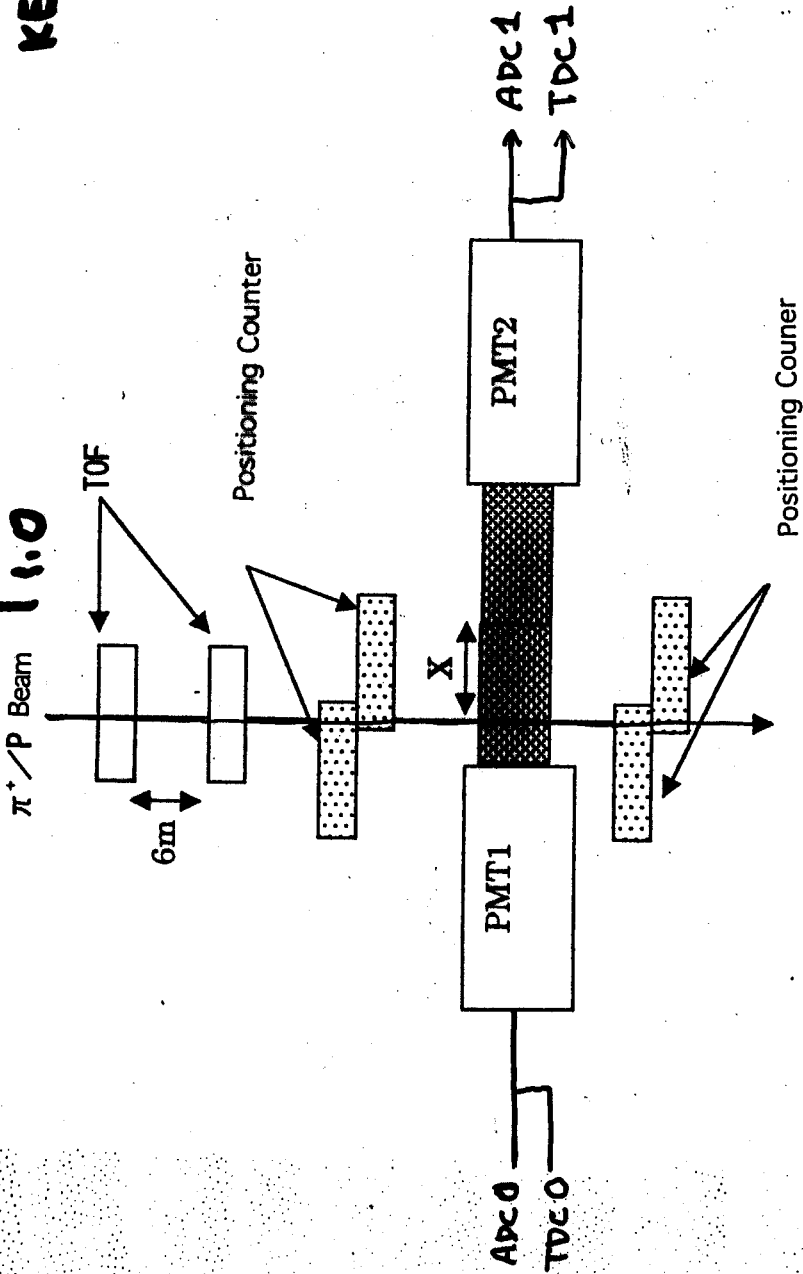

↓ ~ 3 mm  
← ~ 3 mm  
beam

40ms

Stop

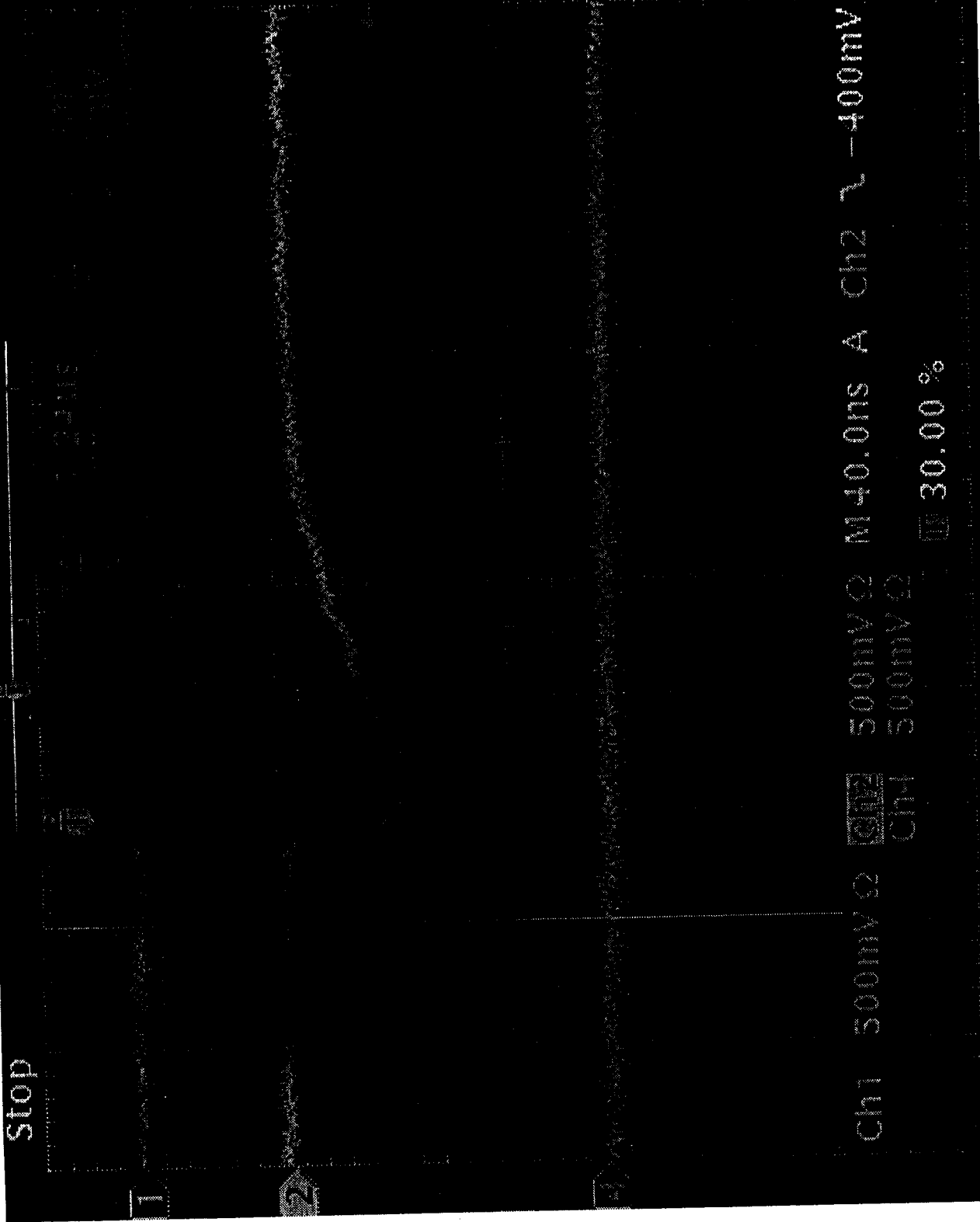

CH1 500mV  $\Omega$  CH2 500mV  $\Omega$  M40.0ns A CH2  $\sim$  -400mV  
CH1 500mV  $\Omega$  CH2 500mV  $\Omega$  30.00 %

GSO-0340

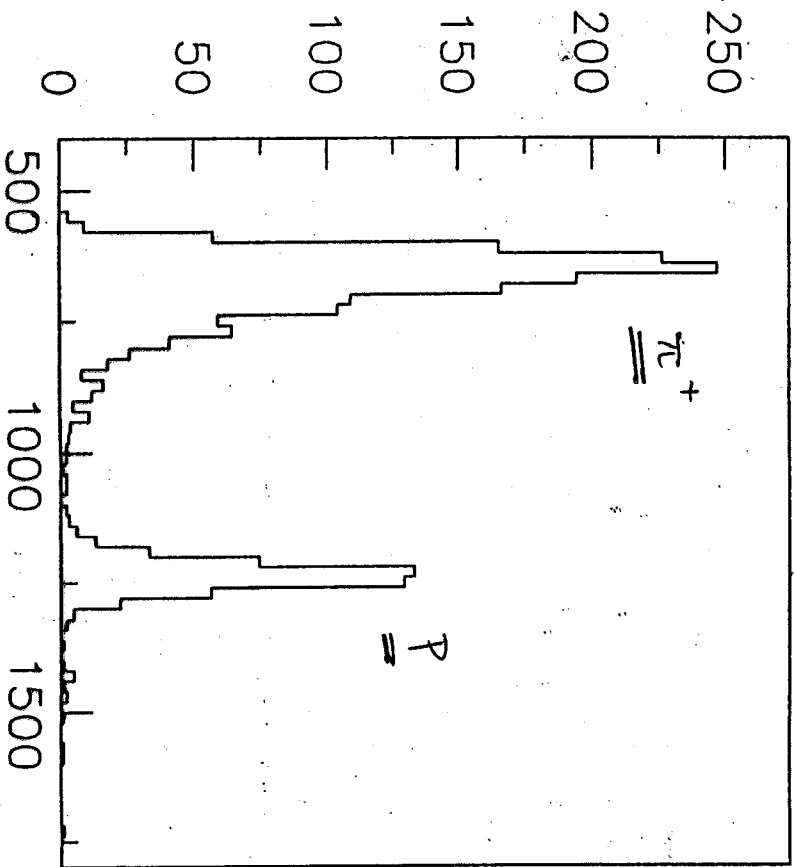

g0-293

(ADC)

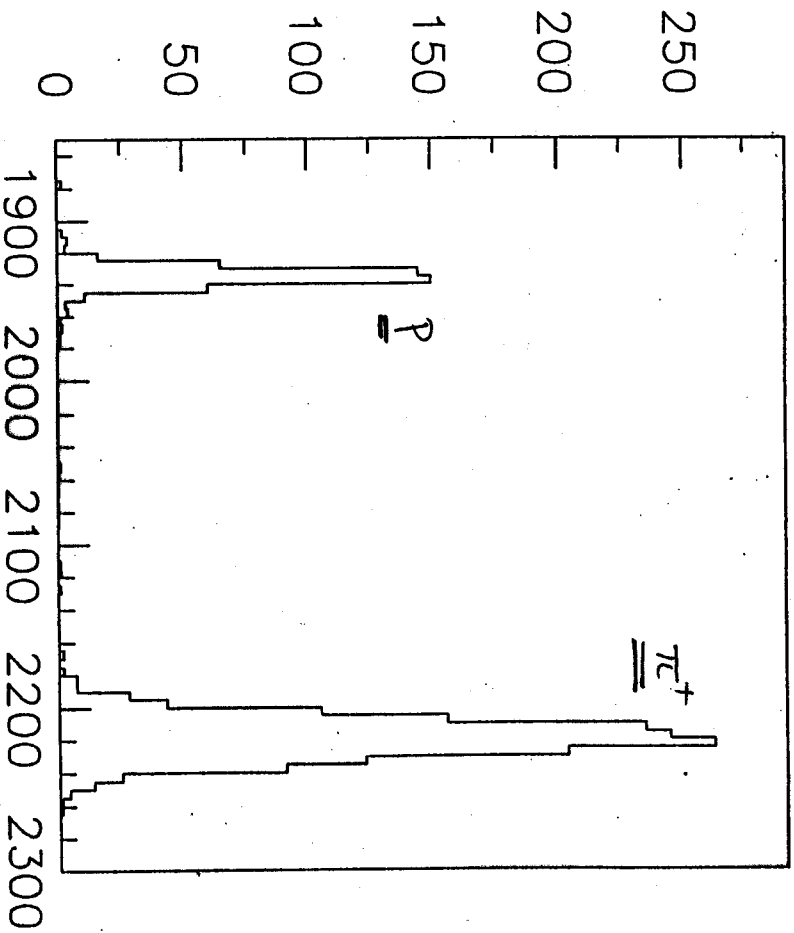

t4

(TDC)

Total Signal Intensity (A0+A1)  
GSO (2cmx2cm, 0.5mol%Ce)  
proton (1.0GeV/C)

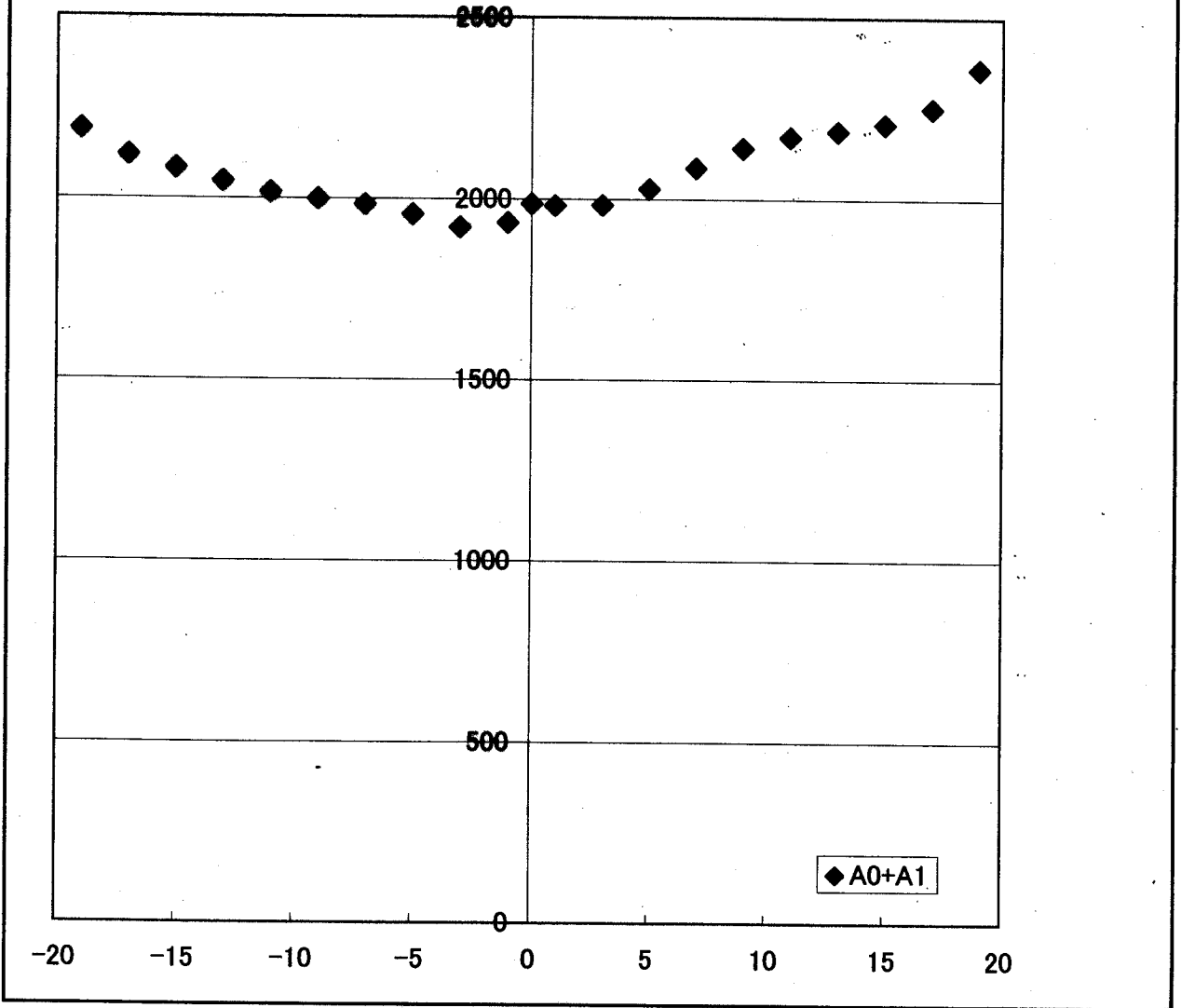

Energy Resolution (A0,A1,A0+A1)  
GSO (2cmx2cmx20cm Double, 0.5mol%:Ce)  
proton (P=1.0GeV/C)  
#0297-#0318

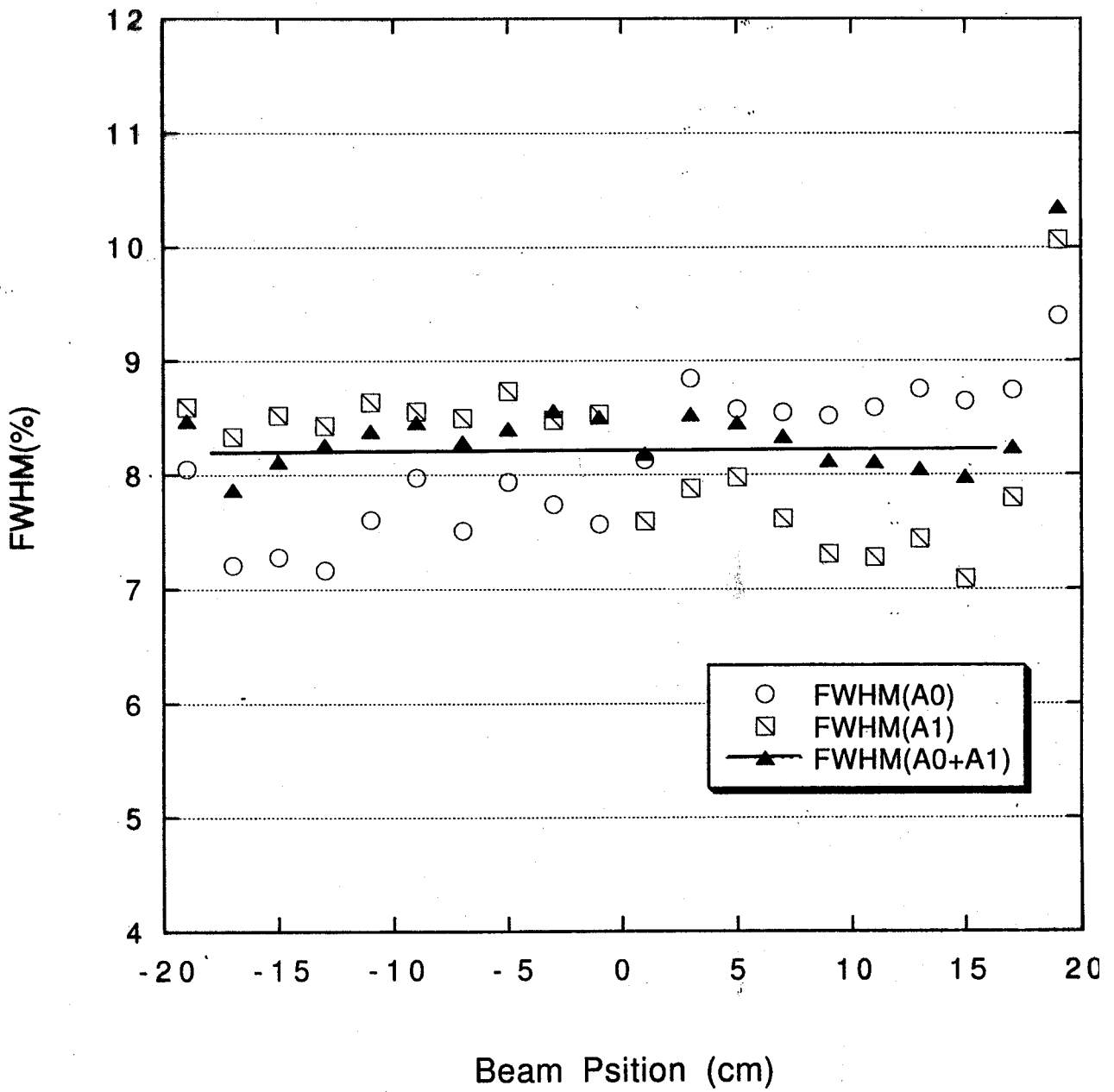

**Signal Intensity (A0,A1)**  
**GSO (2cmx2cmx20cm double, 0.5mol%Ce)**  
**proton (P=1.0GeV/C)**  
**#297-#318**

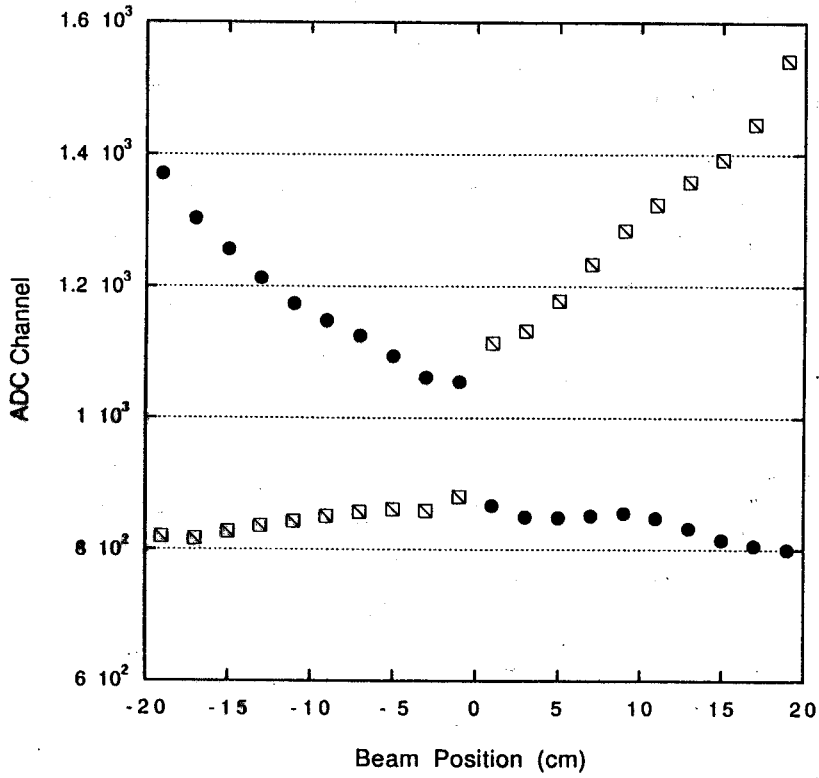

**Signal Intensity Ratio (A0/A1)**  
**GSO (2cmx2cmx20cm Double, 0.5mol%)**  
**proton (P=1.0GeV/C)**  
**#0297-#0318**

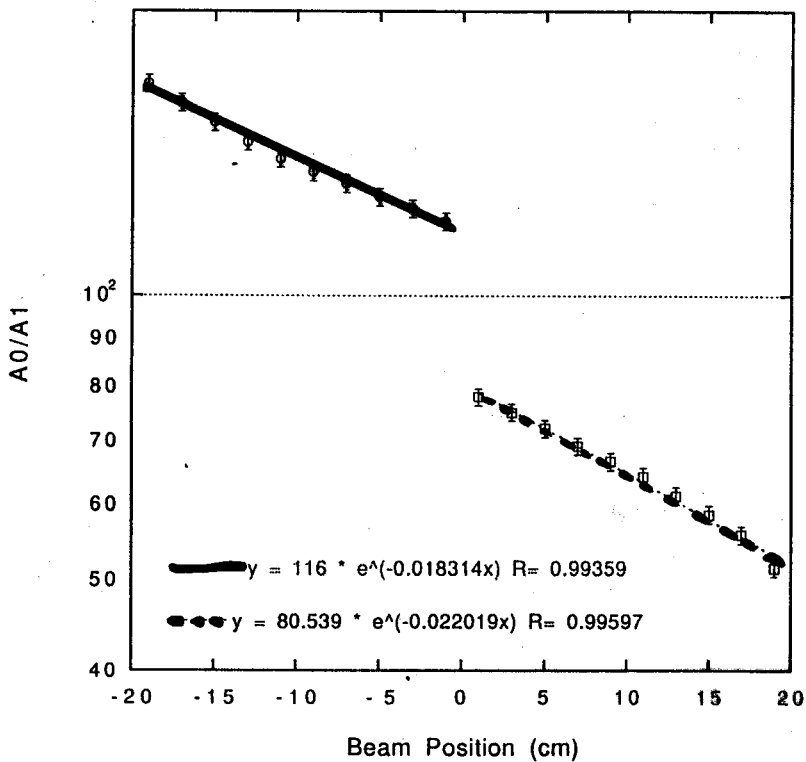

**Energy Resolution**  
**GSO(2cmx2cmx20cm, double, 0.5%mol%:Ce)**  
**proton (p=0.6GeV/C)**  
**#0332-#0344**

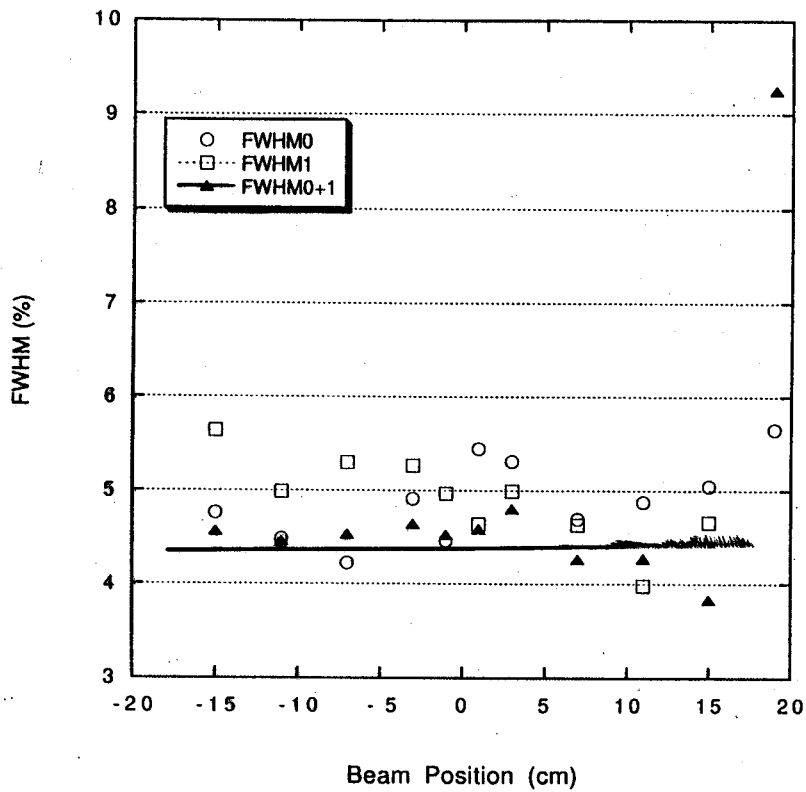

**Signal Intensity Ratio**  
**GSO(2cmx2cmx20cm, double, 0.5%mol%:Ce)**  
**proton (p=0.6GeV/C)**  
**#0332-#0344**

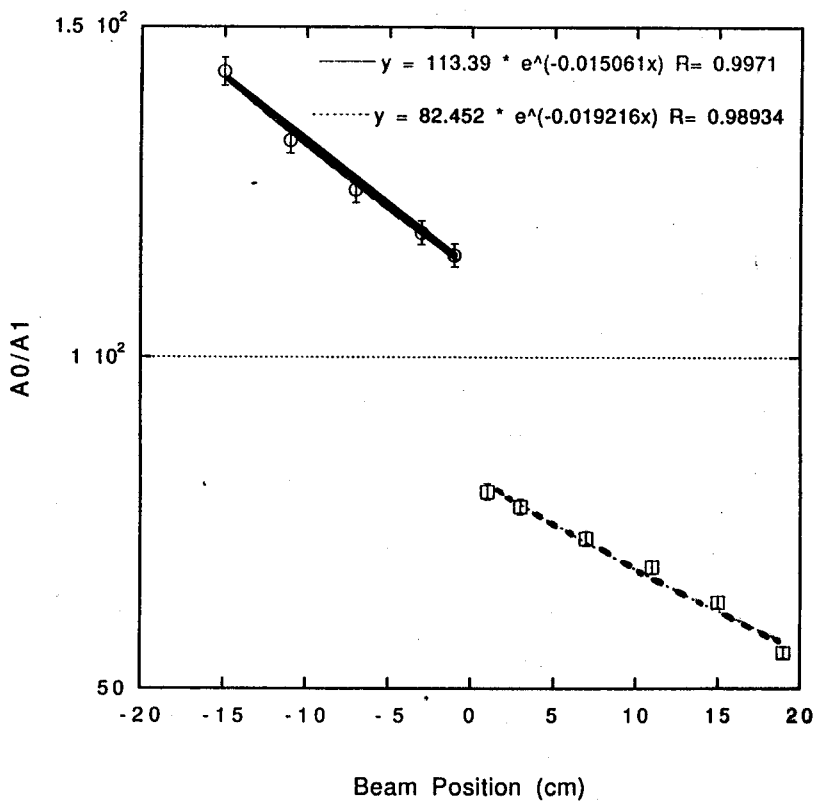

Signal Timing  
GSO 2cmx2cmx20cm Double, 0.5mol%:Ce  
#297-#318

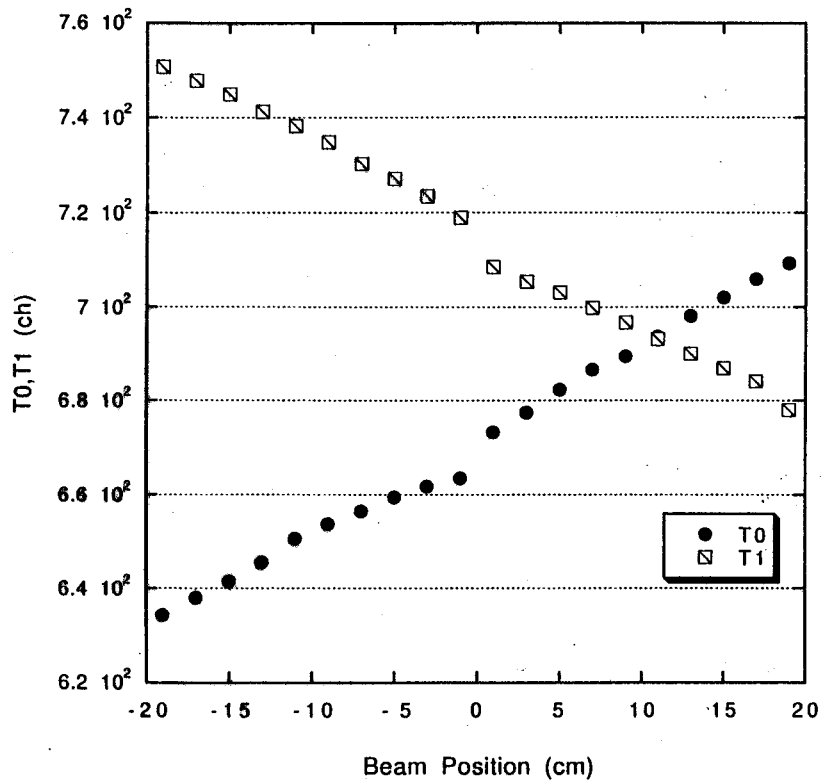

Signal timing (T0-T1)  
GSO (2cmx2cmx20cm Double, 0.5mol%)  
proton (P=1.0GeV/C)  
#0297-#0318

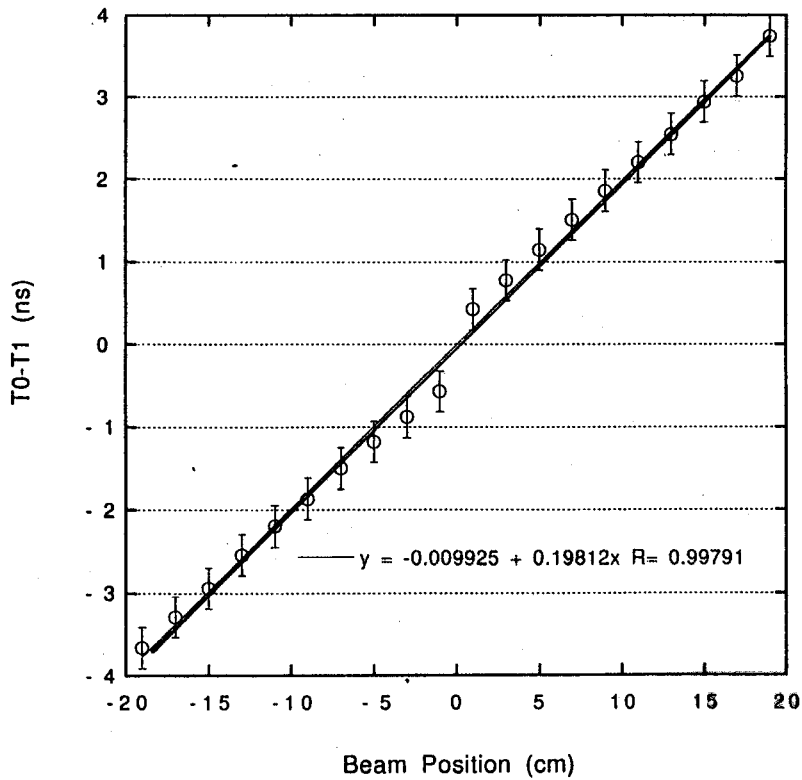

**Signal Timing**  
**GSO(2cmx2cmx20cm, double, 0.5%mol%:Ce)**  
**proton (p=0.6GeV/C)**  
**#0332-#0344**

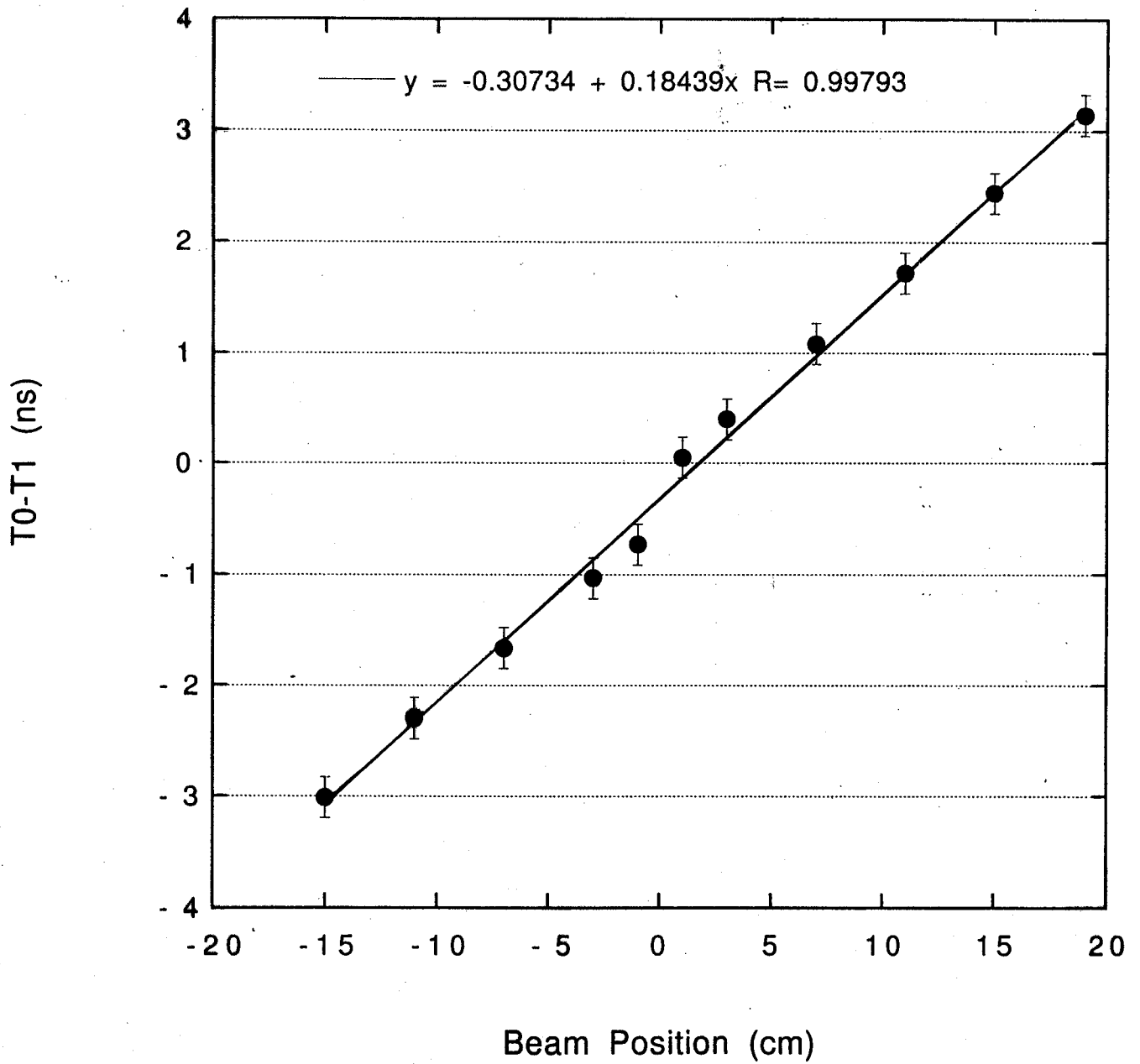

**Signal Intensity**  
**GSO (1cmx1cmx20cm+Plastic)**  
**proton (p=1.0Gev/C)**

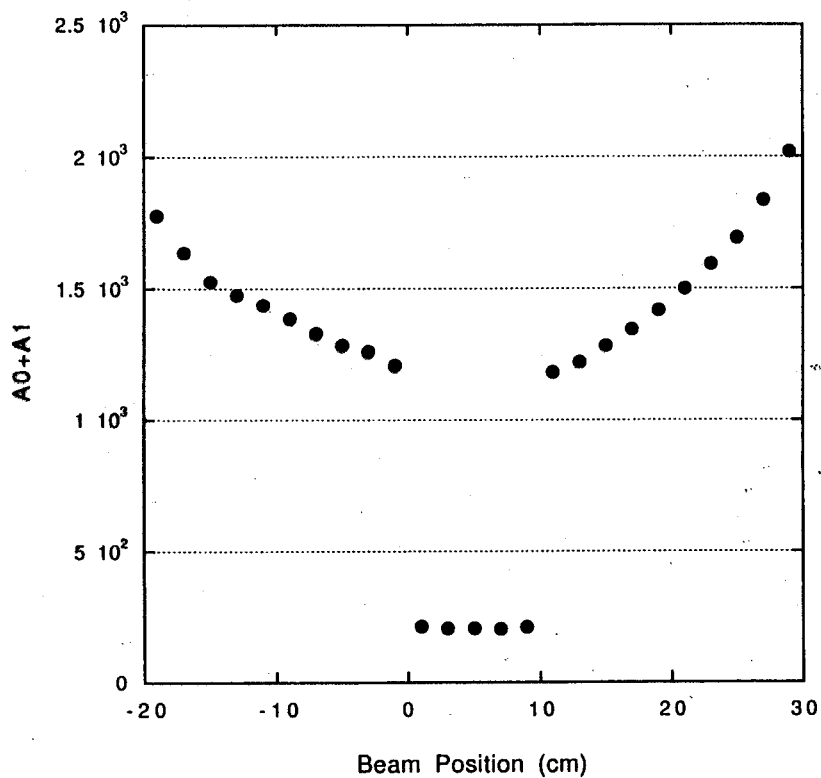

**Energy Resolution**  
**GSO (1cmx1cmx20cm+Plastic)**  
**proton (p=1.0Gev/C)**

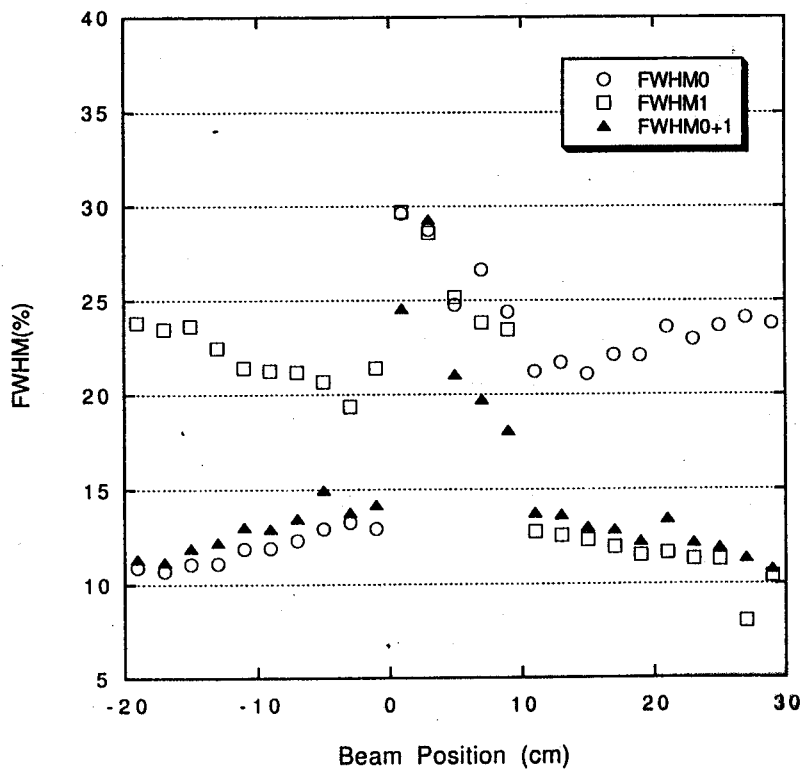

**Signal Intensity Ratio A0/A1  
GSO (1cmx1cmx20cm+Plastic)  
proton (p=1.0Gev/C)**

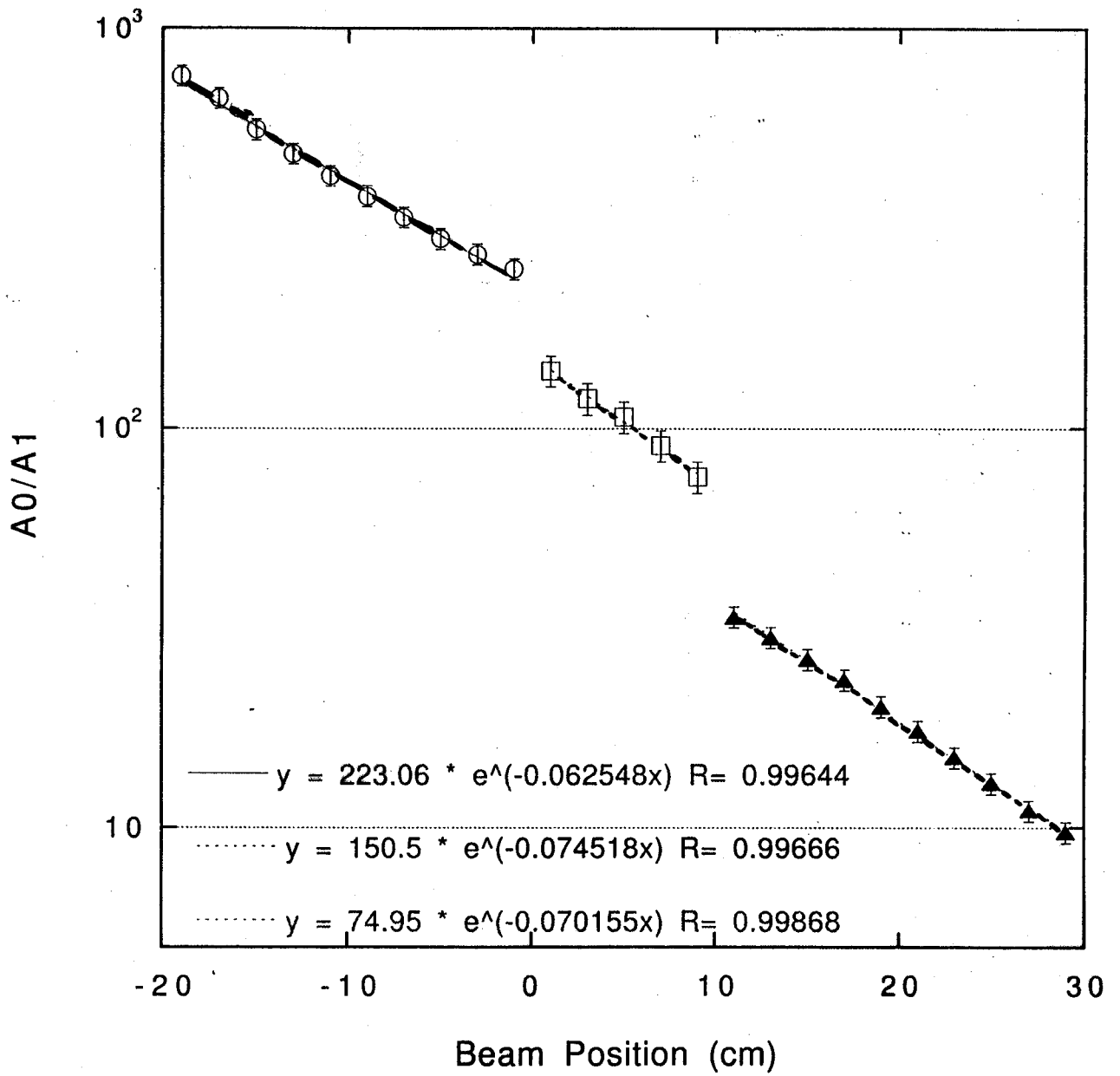

**Signal Timing**  
**GSO (1cmx1cmx20cm+Plastic)**  
**proton (p=1.0Gev/C)**

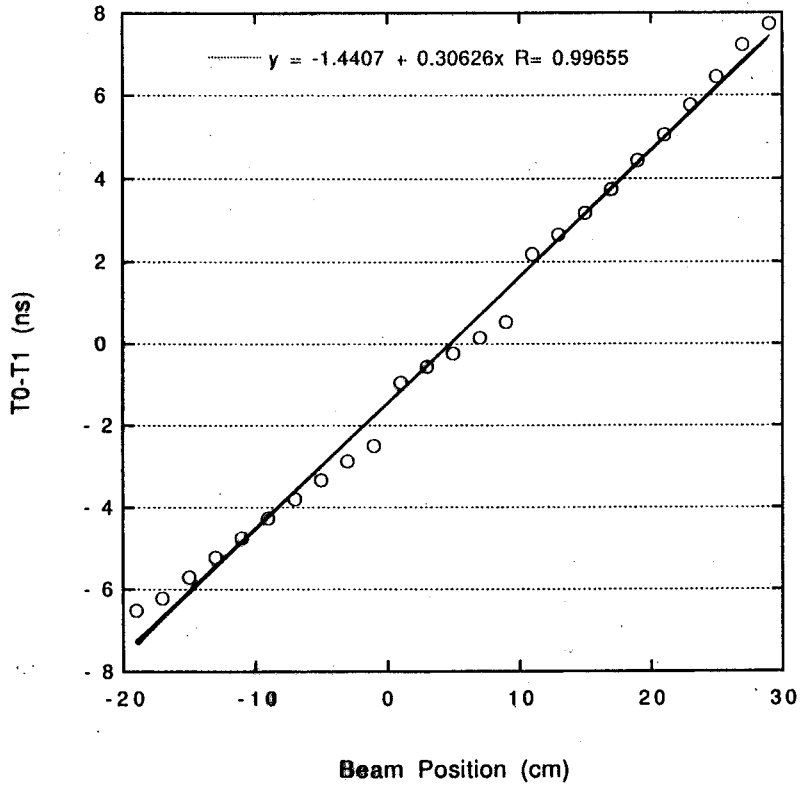

**Signal Timing**  
**GSO (1cmx1cmx20cm+Plastic)**  
**proton (p=1.0Gev/C)**

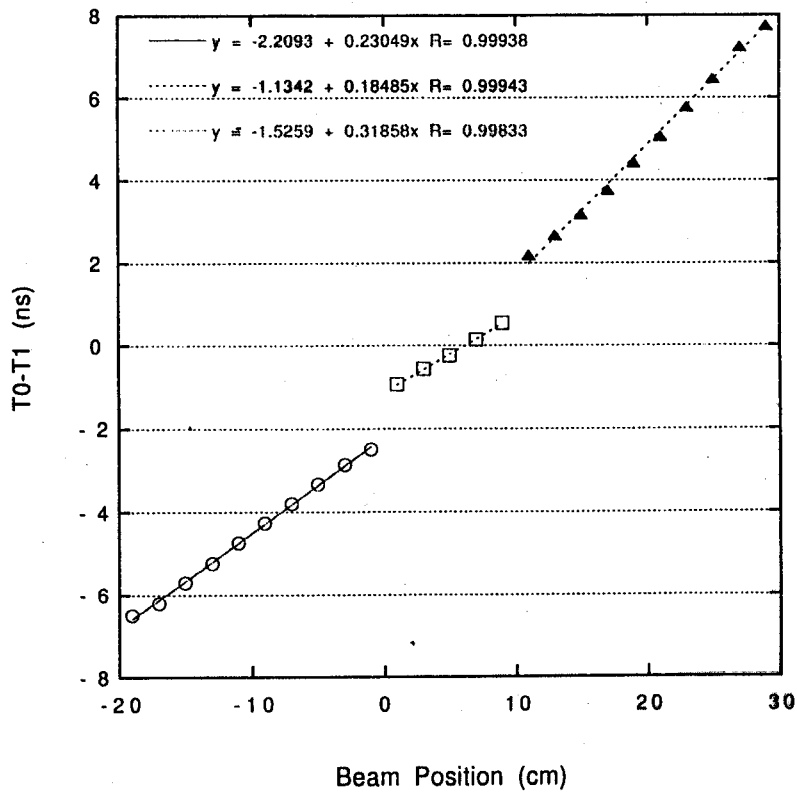

## Results

### 1. Energy Resolution ( $\sigma$ )

	0.6GeV/C	0.8GeV/C	1.0GeV/C	$\gamma$ (0.66MeV)
0.5mol%:Ce, 2cm	1.5% (5.4%)	2.7% (5.5%)	3.5% (5.5%)	7.5%
1.5mol%:Ce, 2cm		2.8% (5.5%)	3.8% (6.0%)	9.1%
1.5mol%:Ce, 1cm			5.1% (7.7%)	

proton (pai+)

### 2. Signal Intensity Ratio ( $A_0/A_1$ ) 1.0GeV/C(proton)

	Coefficient(/cm)	Position Resolution( $\sigma$ )
0.5mol%:Ce, 2cmx2cm	0.020	1.05 cm
1.5mol%:Ce, 2cmx2cm	0.037	0.75 cm
1.5mol%:Ce, 1cmx1cm	0.068	0.61 cm

$$A_0/A_1 = c \cdot e^{-ax}$$

### 3. Signal Timing ( $T_0-T_1$ ) 1.0GeV/C(proton)

	Coefficient(ns/cm)	Position Resolution( $\sigma$ )
0.5mol%:Ce, 2cmx2cm	0.20	1.5 cm
1.5mol%:Ce, 2cmx2cm	0.21	2.9 cm
1.5mol%:Ce, 1cmx1cm	0.42	1.4 cm

$$(T_0 - T_1) = ax + b$$

### What can I say.

1. Light contact is important !

Signal Intensity, Resolution, ...Reflection...

2. If we can decide the function ( $A_0/A_1, T_0-T_1$ : position dependence),

Small crystal has better position resolution.

Ce-rich crystal has better position resolution

3. Small crystal seems to have a bad Energy-Resolution (FWHM), but,

When we can see the Absolute width of  $dE$ , the small crystal has a same value to bigger crystals.

### What I will do...

Try to good light contact material ( method )

X-Y position Resolution

Some simulation about trucking in the stacking detectors

## Edeposit\_GSO

### GEANT3

energy deposit in GSO (2cmx2cmx20cm)

P(Gev/C)	p-mean	pai-mean	pai-peak	p/pai-m	p/pai-p
1.00	24.10	18.44	15.95	1.31	1.51
0.80	29.62	17.65	15.90	1.68	1.86
0.60	44.28	17.28	18.13	2.56	2.44

energy Deposit in PWO(2cmx2cmx2cm)

P(Gev/C)	p-mean	pai-mean	pai-peak	p/pai-m	p/pai-p
1.00	<b>28.88</b>	20.51	18.44	1.41	1.57
0.80	<b>32.82</b>	20.17	18.33	1.63	1.79
0.60	<b>49.08</b>	<b>19.46</b>	18.21	2.52	2.70
0.5	<b>88.97</b>	19.37	18.2		

d(mean)

1	60.32
---	-------

### Experiment(GSO)

p-mean	pai-mean	pai-peak	d-mean	d-peak	p/pai-m	p/pai-p
4335.00	3573.00	3330.00			1.21	1.30
4487.00	3302.00	3360.00			1.36	1.34
6139.00	3302.00	3386.00			1.86	1.81