

T. K. Komatsubara

KEK-IPNS

Kaon Decay Workshop @KEK February'01

Exotic Search at the BNL E787-E949

Outline :

- Search for the ultra-rare decay $K^+ \rightarrow \pi^+ \gamma$ in E787, and Prospects for the search in E949

- An apéritif talk for entertainment.

Physics of Kaon Decays from E787

$K^+ \rightarrow \pi^+ \nu \bar{\nu}$	observed	2000	SM Flavor dynamics
$K^+ \rightarrow \pi^+ f$	limit	2000	family, beyond the SM
$K^+ \rightarrow \pi^+ H, H \rightarrow \mu^+ \mu^-$	limit	1989	SM light Higgs
$K^+ \rightarrow \pi^+ \gamma \gamma$	observed	1997	ChPT
$K^+ \rightarrow \pi^+ \mu^+ \mu^-$	observed	1997	ChPT
$K^+ \rightarrow e^+ \nu \mu^+ \mu^-$	limit	1998	ChPT
$K^+ \rightarrow \mu^+ \nu \gamma$	measured	2000	ChPT
$K^+ \rightarrow \pi^+ \pi^0 \gamma$	measured	2000	ChPT
$K^+ \rightarrow \pi^+ \pi^0 \nu \bar{\nu}$	limit	2001	SM, initial search
$K^+ \rightarrow \mu^+ \pi^0 \nu \gamma$			ChPT, in progress

- Three or four-body decays
- final states with $\pi^+ / \mu^+ / \gamma (\pi^0)$'s
- main mode to test the SM, and byproducts to check the ChPT

Any anomalous/exciting bread-and-butter physics

STRING THEORY IS TESTABLE, EVEN SUPERTESTABLE

Many believe that superstring theory, because of its extraordinarily tiny length scale and gargantuan energy scale, cannot be tested. That belief is a myth.

Gordon Kane



"BUT DON'T YOU SEE, GERSHON — IF THE PARTICLE IS TOO SMALL AND TOO SHORT-LIVED TO DETECT, WE CAN'T JUST TAKE IT ON FAITH THAT YOU'VE DISCOVERED IT."

being different for general relativity and classical gravity, anti-particles from unifying quantum theory and special relativity, and nucleosynthesis and the microwave background radiation for the Big Bang theory of the universe. Of course, I cannot say what the unexpected tests will be for the primary theory, but I can list some candidates that might occur:

▷ Perhaps the number of particle families will be related to the number of space dimensions or to the Yukawa coupling (and therefore mass) of the heaviest fermion (the top quark) or to some other observable, as happens in models.

▷ Some of the scalar fields are expected to be massless until the supersymmetry is broken. Some of the scalars may remain very light, and give rise to long-range forces or contribute to neutrino masses in a predictable way.

▷ Some interactions that are forbidden in any point-particle quantum field theory can occur in string theory. For example, certain quantities described by Lorentz tensors in the theory can acquire nonzero vacuum expectation values. This breaks Lorentz invariance and CPT symmetry. In models, such effects could appear at detectable levels in the neutral K, D and B systems, or in decays such as $K^+ \rightarrow \pi^+ + \gamma$, or in appropriate atomic or nuclear systems.

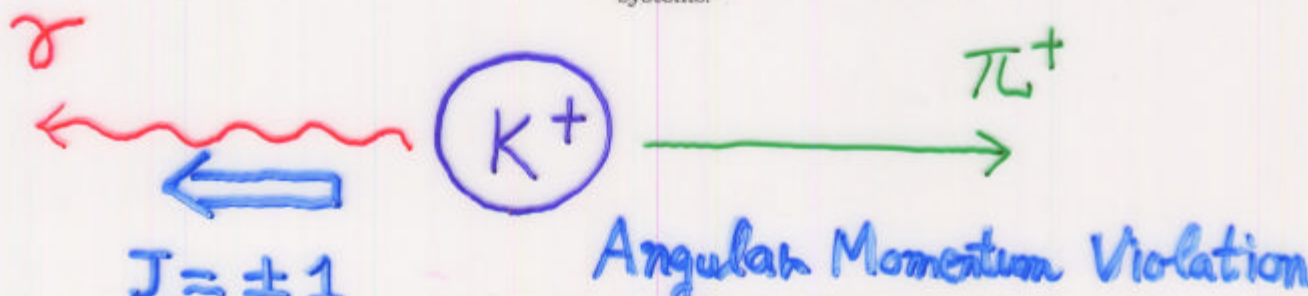

$$\text{Br}(K^+ \rightarrow \pi^+ \gamma)$$

Theory

Experiment @90%

$$\ll \text{Br}(K^+ \rightarrow \pi^+ \pi^0)$$

'56 Dalitz
 K^+ spin=0

'69 Selleri
 K^+ spin= $\frac{1}{2}$
and AngMomV decay
 2×10^{-4}

'70

Bevatron
 $< 4 \times 10^{-6}$

'82

KEK E10
 $< 1.4 \times 10^{-6}$

no candidate even

'88 Kane
vacuum expectation value

'97 Kane
non-local Superstring effects

'99 Coleman-Glashow
departures from Lorentz invariance
GZK cutoff to the UHE cosmic rays

no theoretical prediction

A NEW EXPERIMENTAL LIMIT FOR THE DECAY $K^+ \rightarrow \pi^+ \gamma \gamma$ Y. ASANO ^{a,1}, E. KIKUTANI ^b, S. KUROKAWA ^a, T. MIYACHI ^c, M. MIYAJIMA ^a,
Y. NAGASHIMA ^d, T. SHINKAWA ^{b,2}, S. SUGIMOTO ^{a,3} and Y. YOSHIMURA ^a^a KEK, National Laboratory for High Energy Physics, Oho-machi, Tsukuba-gun, Ibaraki 305, Japan^b Department of Physics, Faculty of Science, University of Tokyo, Bunkyo-ku, Tokyo 117, Japan^c Institute for Nuclear Study, University of Tokyo, Tanashi, Tokyo 188, Japan^d Department of Physics, Faculty of Science, Osaka University, Machikaneyama-cho, Toyonaka 560, Japan

Received 25 March 1982

A search for $K^+ \rightarrow \pi^+ \gamma$, $\pi^+ \gamma \gamma$, $\pi^+ \gamma \gamma \gamma$ was made detecting pions from stopped kaons in the kinetic energy region between 117 MeV and 127 MeV. New limits of 1.4×10^{-6} , 8.4×10^{-6} and 1.0×10^{-4} for the branching ratio were obtained assuming a phase-space spectrum on the pion energy. The first limit also applies to another process $K^+ \rightarrow \pi^+ + a$, where a is a light meson with mass smaller than $100 \text{ MeV}/c^2$ and decays into $n\gamma$'s with lifetime less than 10^{-9} s .

In a general treatment of rare decay modes of kaons within the realm of the standard electro-weak theory, Gaillard and Lee [1] discussed the process $K^+ \rightarrow \pi^+ \gamma \gamma$ and gave an estimate of order of $G_F \alpha$ or 10^{-6} – 10^{-7} for the branching ratio. However, the argument appears a posteriori less reliable compared to other processes like $K_L^0 \rightarrow \mu \bar{\mu}$, $K^+ \rightarrow \pi^+ \nu \bar{\nu}$, $K^0 \rightarrow \bar{K}^0$ and similar estimates were obtained from low-energy phenomenology of the pre-Weinberg–Salam era [2–5]. Different models gave widely varying decay rates ranging from 10^{-4} to 10^{-8} . Earlier experiments [6–9] have ruled out some of the larger predictions. The best limit obtained so far is 3.5×10^{-5} . We report here a new limit on the branching ratio.

The experiment was performed in conjunction with searches for $K^+ \rightarrow \mu^+ \nu_H$ (heavy neutrino), $K^+ \rightarrow \pi^+ \nu \bar{\nu}$ and $K^+ \rightarrow \pi^+ + \text{axion}$ [10]. Details of the apparatus were already reported. Briefly, we detected a pion accompanied with any number of photons emitted by a kaon. The kinetic energy of the pion was required to be above that of $K^+ \rightarrow \pi^+ \pi^0$, namely $117 < T_\pi < 127$

MeV. A partially separated beam at KEK provided approximately 34000 positive kaons per pulse at 530 MeV/c. Half of them were stopped within a target consisting of seven layers (T_1 – T_7) of scintillation counters (16 cm wide \times 10 cm long \times 1 cm thick). Emitted pions went into a range telescope and were stopped in one of seven layers (M_1 – M_7) of the range counter (100 cm \times 100 cm \times 1 cm). They were identified by observing $\pi \rightarrow \mu \rightarrow e$ cascade decay, although the presence of the positron was not required in the final analysis. Four sets of multi-wire proportional chambers were used to define the trajectory of the pion. The materials and trigger logic were almost identical to those used for the decay $K^+ \rightarrow \pi^+ \nu \bar{\nu}$ except that the signals from the lead-glass Čerenkov counters were in coincidence in the search for $K^+ \rightarrow \pi^+ \gamma \gamma$ and that an extra matrix logic (some combination of $T_i \cdot M_j$) was added. The latter was introduced to reduce large backgrounds from $\pi^+ \pi^0$ to a controllable level (1.7/pulse). Since the trigger logic was activated during only the last fraction of the beam spill which was used primarily to search for $K^+ \rightarrow \pi^+ \nu \bar{\nu}$, the effective number of stopped kaons per pulse was only 440. A total of 3.8×10^8 of them were collected altogether. As the trigger allowed presence of a charged particle plus photons, collected events were mainly from $K^+ \rightarrow \pi^+ \pi^0$ and $K^+ \rightarrow \mu^+ \nu^0$. The decay $K^+ \rightarrow \mu^+ \nu \gamma$ was known to be negligible from the previous

¹ Now at Institute of Applied Physics, University of Tsukuba, Niihari-gun, Ibaraki, Japan.² Now at Brown University, Providence, RI 02912, USA.³ Now at Osaka University, Machikaneyama-cho, Toyonaka 560, Japan.

E-787 Spectrometer

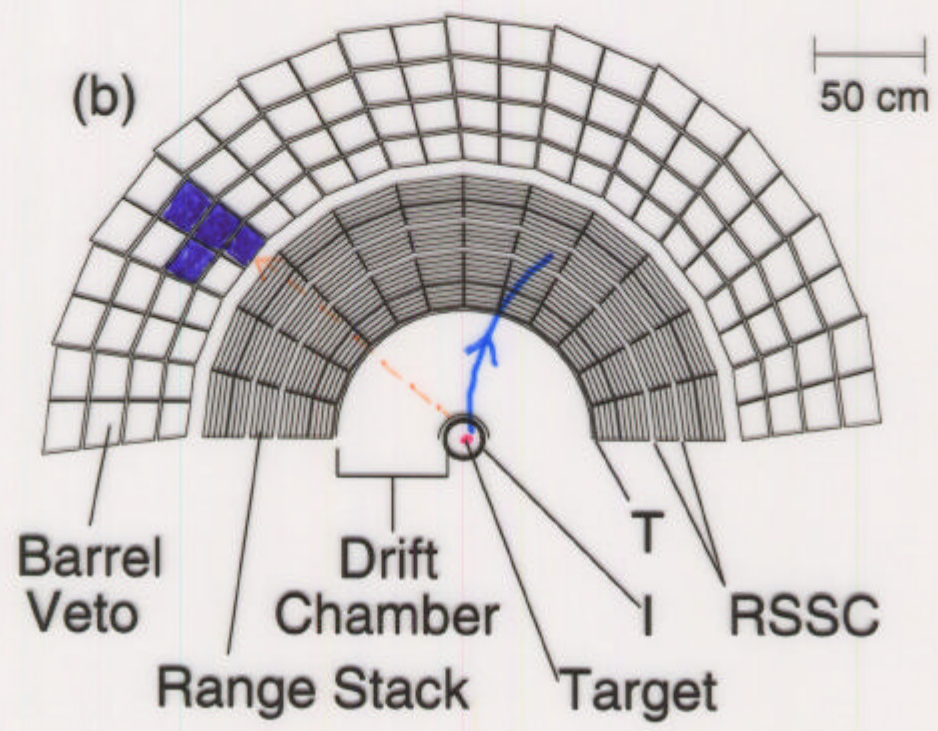
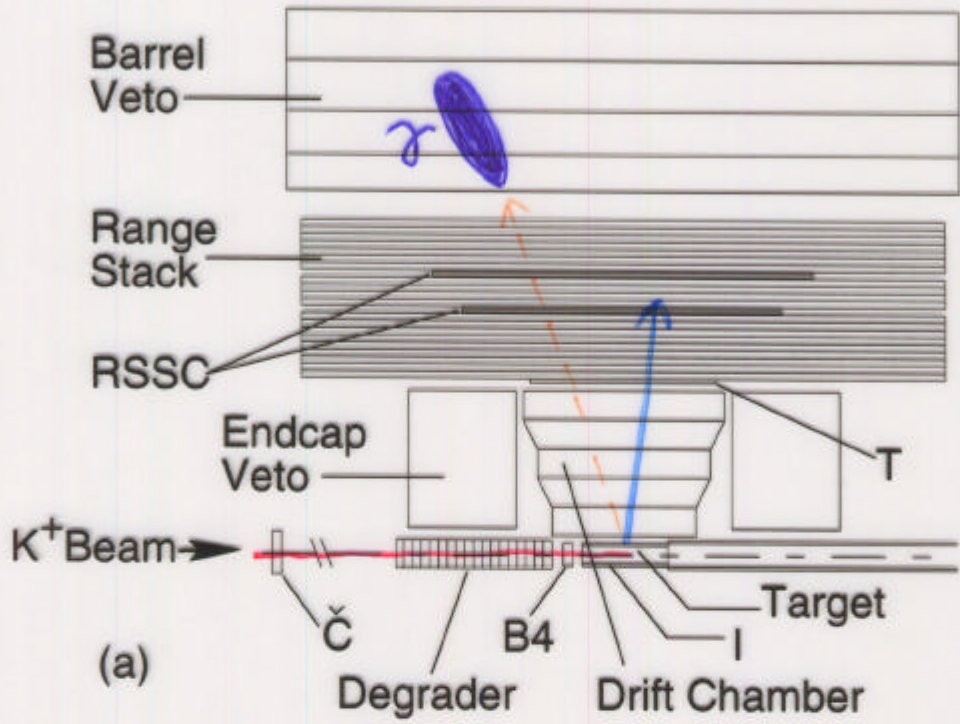

stopped K^+ decay to π^+ plus γ

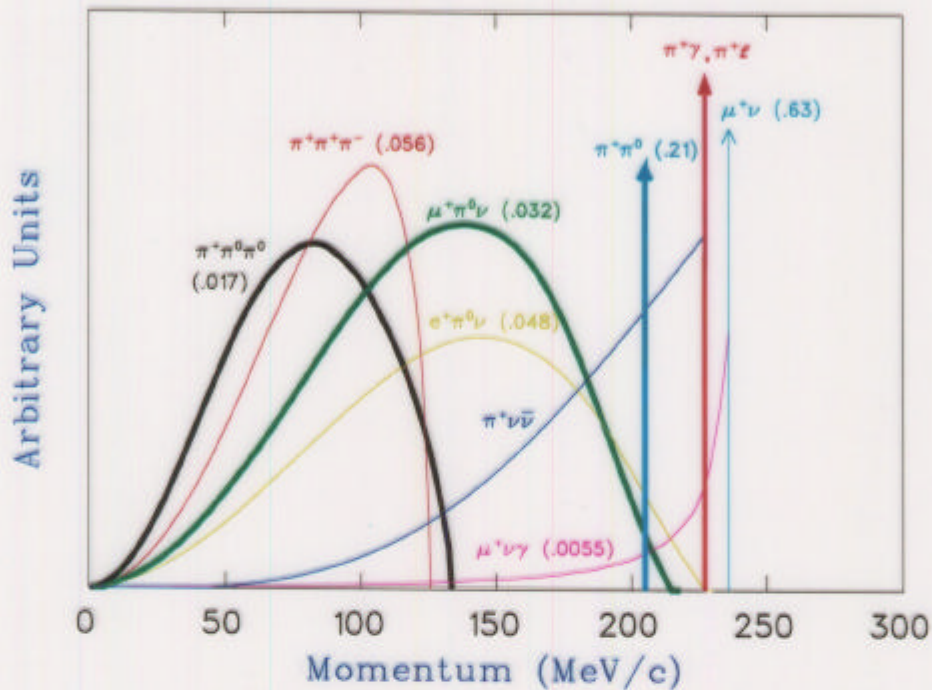

KB · DC · IC_T • 2 · (6_{ct} + 7_{ct}) · (19_{ct} + 20_{ct} + 21_{ct}) · L1.n · HEX

• $\overline{ECL0} \cdot \overline{BV} \cdot L0\text{-z-mask} \Rightarrow \text{pnn}(1)$ trigger

• $\overline{ECL0} \cdot \overline{BV} \cdot \overline{NG2} \Rightarrow 1\text{gamma}$ trigger

kaon exposure: 6.7×10^8 , triggers: 1.6×10^6
(in '96 and '97, prescaled by 2450, ~ 1 event/spill).

• $\pi^+ \rightarrow \mu^+$ decay in the stopping scintillator [loose TD cut]
 \Rightarrow negligible background from

– μ^+/e^+ track ($e^+ \pi^0 \nu$, $\mu^+ \pi^0 \nu$, $\mu^+ \nu \gamma$, $\mu^+ \nu$ + accidental)

– π^+ decay-in-flight.

potential background source: $K^+ \rightarrow \pi^+ \pi^0$ ($K_{\pi 2}$)

$K^+ \rightarrow \pi^+ \gamma$ decay in Monte Carlo

KPI2(11)

SCALE 1:16.0



227 MeV
to the
opposite
side



227 MeV/c
127 MeV
38.5 cm



RUN 96071
EVENT 31

$K^+ \rightarrow \pi^+ \pi^0$ background in Monte Carlo

KPI2(11)

SCALE 1:16.0

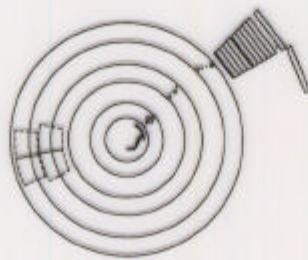

205 MeV/c
smaller



RUN 96031
EVENT 121



$K^+ \rightarrow \pi^+ \gamma$ in MC

E_γ

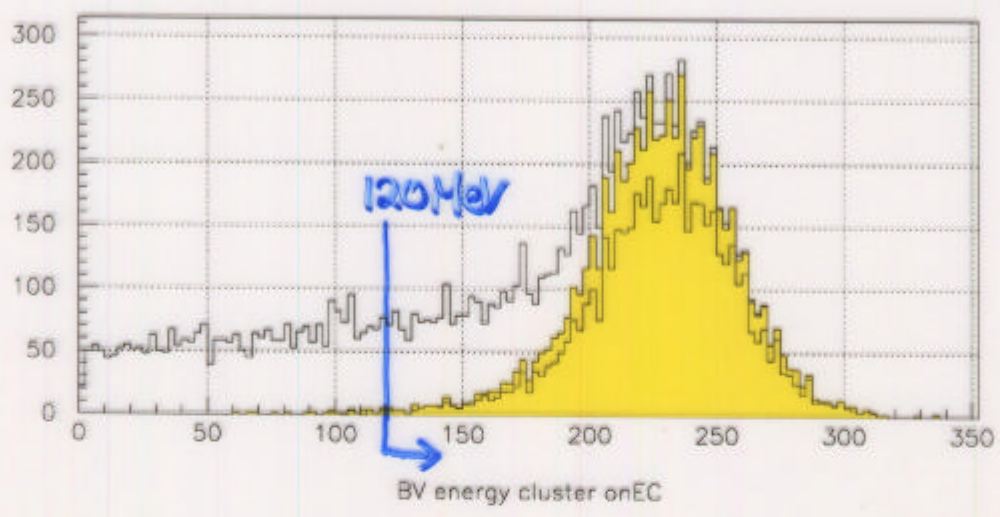

$\cos \theta_{xy}$

$\cos \theta_{RZ}$

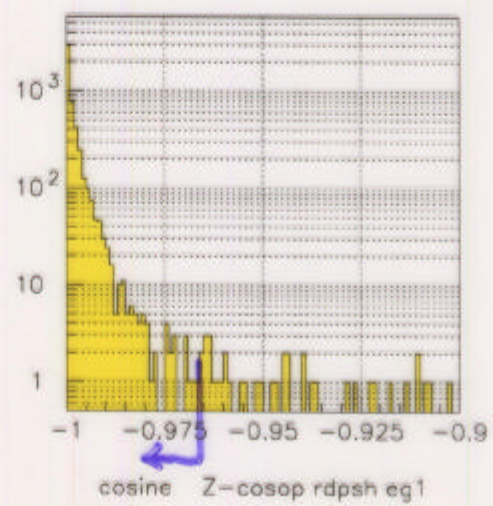
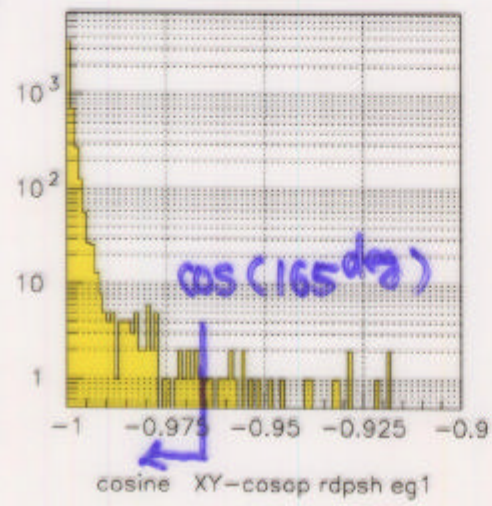

$K^+ \rightarrow \pi^+ \pi^0$ in MC

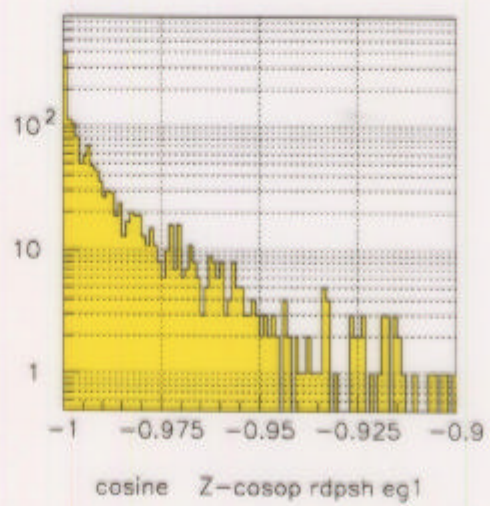
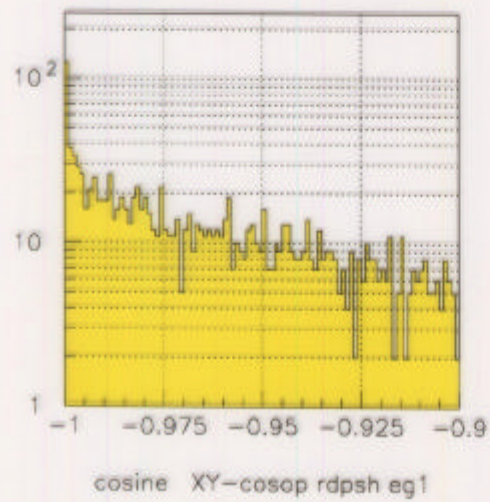
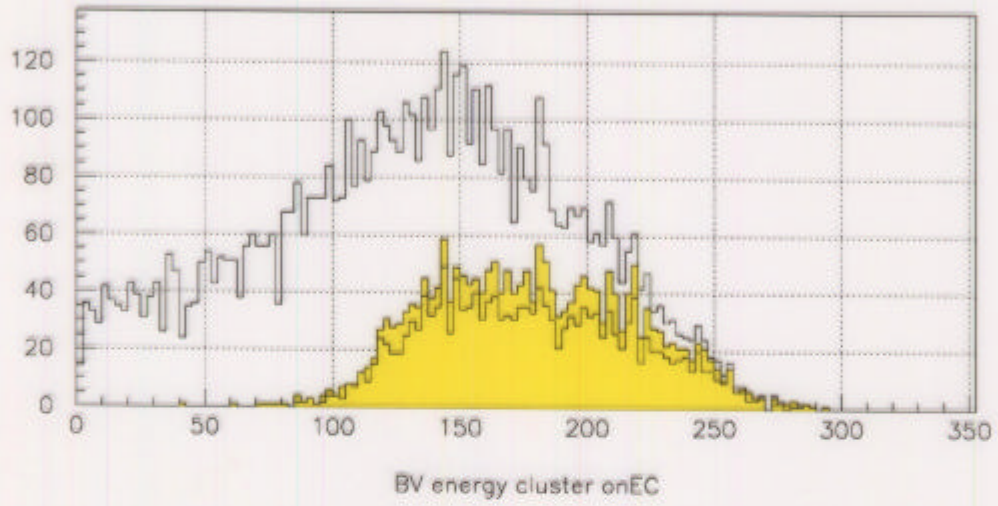

$K^+ \rightarrow \pi^+ \gamma$ decay in Monte Carlo

KPI2(11)

SCALE 1: 16.0

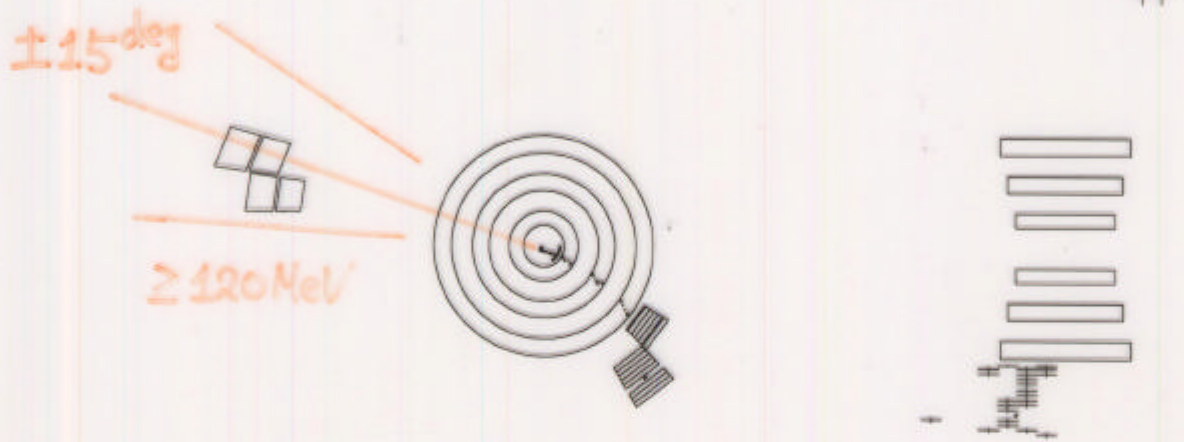

$K^+ \rightarrow \pi^+ \pi^0$ background in Monte Carlo

KPI2(11)

SCALE 1: 16.0

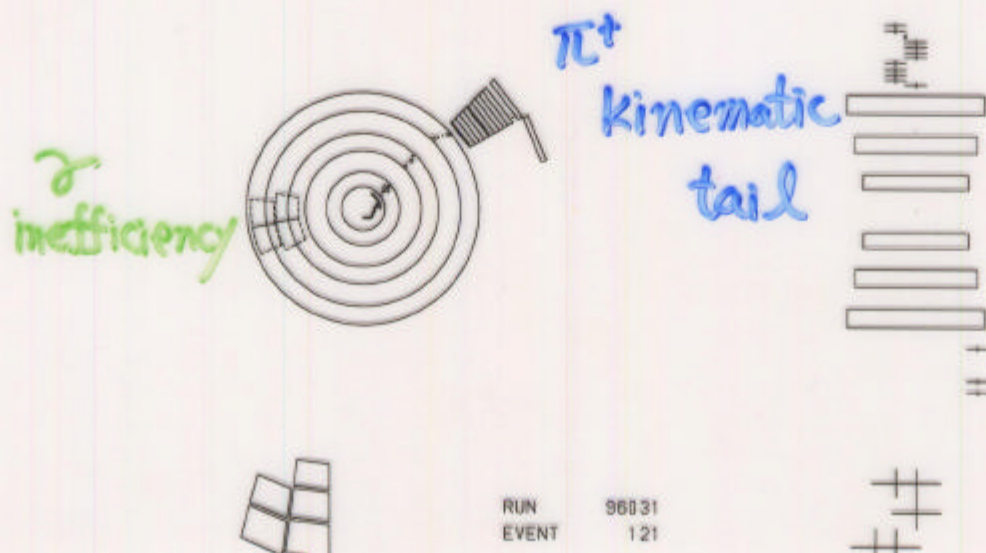

$K^+ \rightarrow \pi^+\pi^0$ ($K_{\pi 2}$) background study

- Kinematics : Momentum/Energy/Rang
- γ Veto (another photon in $\pi^0 \rightarrow \gamma\gamma$)

π^+ and γ to the opposite side

[γ veto reversed]

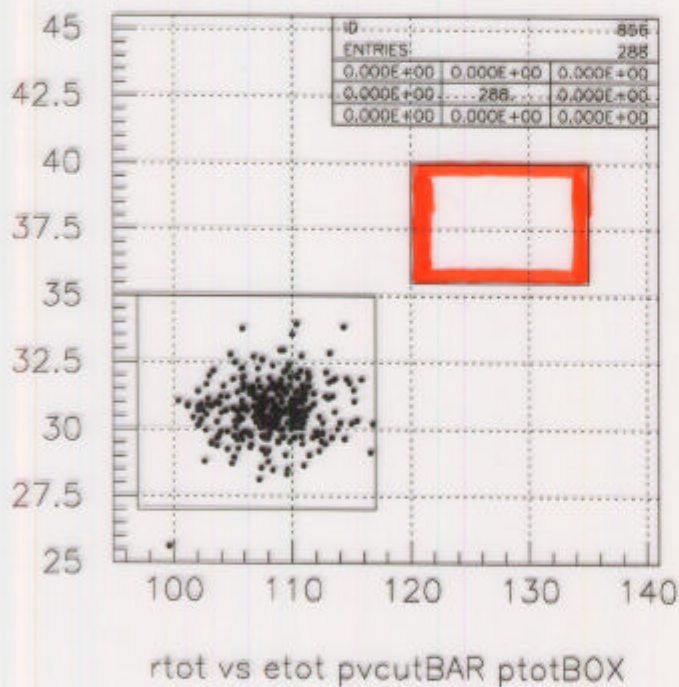

Range-Energy in
 $218 < \text{Momentum} < 234 \text{ MeV}/c$

π^+ kinematic tail: 0 event

[π^+ in $K_{\pi 2}$ peak]

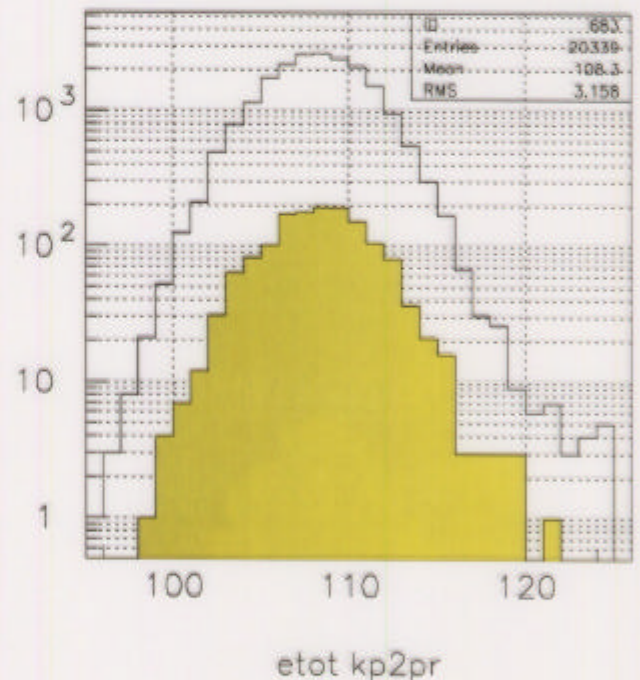

γ veto rejection
 in the offline

$\text{Rej}_{-pV} = 13.8$

$N_{b.g.} < 2.3 / 13.8 = 0.18 \text{ events (90\% C.L.)}$

$K^+ \rightarrow \pi^+ \pi^0: \gamma\gamma$ into the single BV cluster

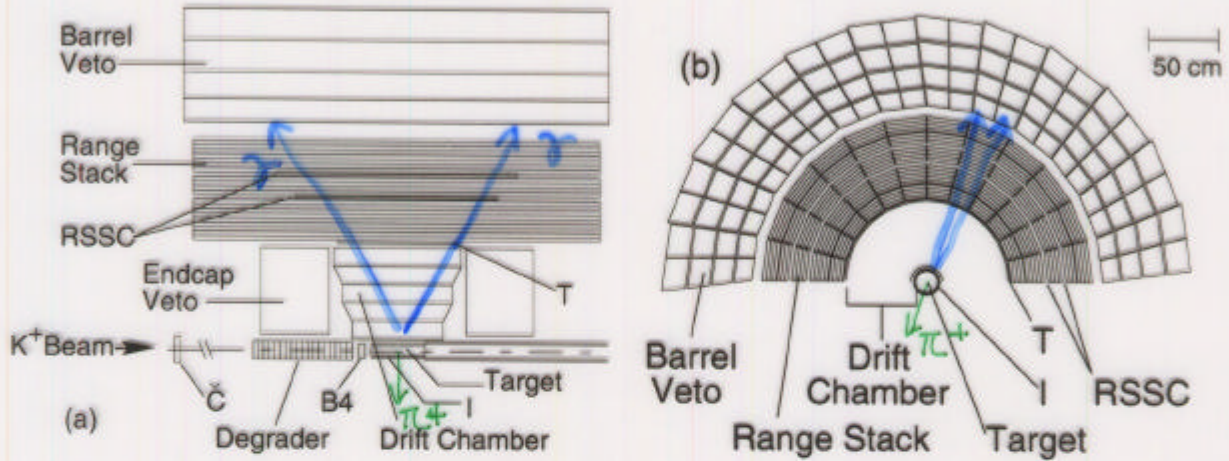

γ veto in the cluster

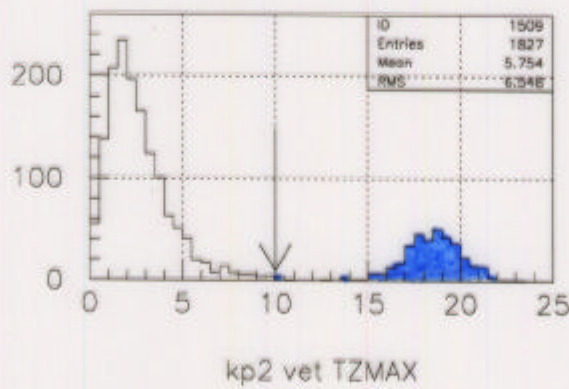

[Rejection] 1.25

[Acceptance loss] 0.1%

$K^+ \rightarrow \pi^+ \pi^0$: low-energy γ overlapping the π^+ track

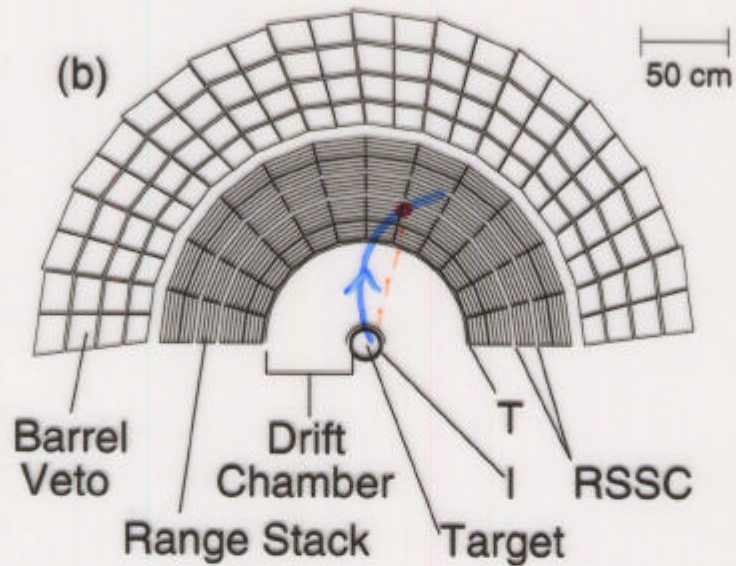

Range Stack dE/dx cut

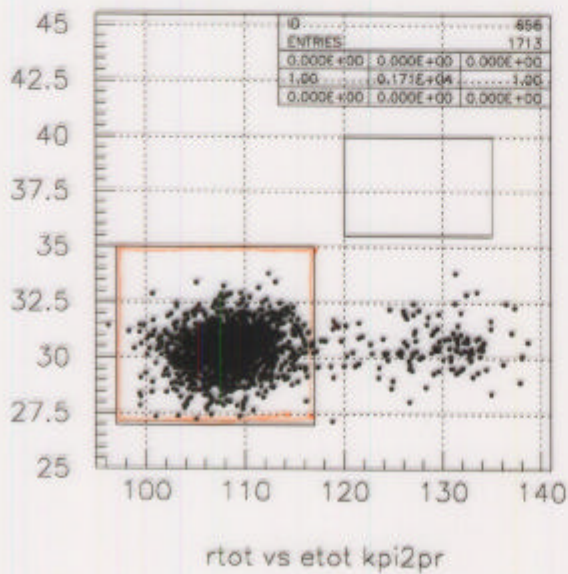

Momentum
in the K_{π^2} peak

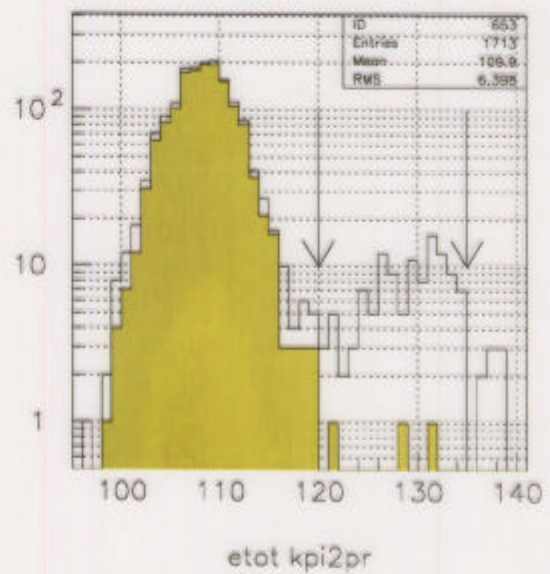

after the dE/dx cut
Rejection 38.0

Range-Energy plot after all the offline cuts:

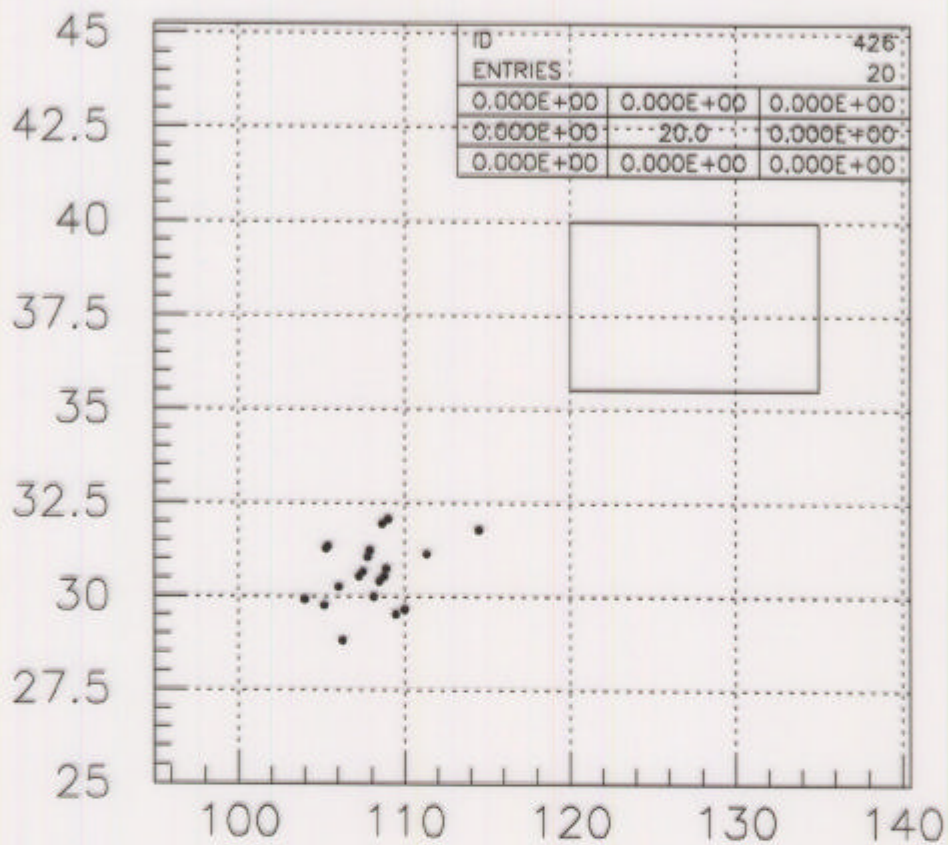

rtot vs etot PtotBOX pv

No event is observed in the signal region

Sensitivity [ratio-measurement]

of $K^+ \rightarrow \pi^+\pi^0$ decays in the 1gamma triggers: 0.362M
(counting $K^+ \rightarrow \pi^+\gamma X$, reconstructed w/o γ veto)

- Acceptance ratio:

$$\frac{A_{\pi\pi}}{A_{\pi\gamma}} = 0.25$$

- $BR(K^+ \rightarrow \pi^+\pi^0) = 0.2116$

Sensitivity: 1.46×10^{-7} (preliminary)
 $\times 4$ better than KEK E10

- The current search is statistically limited.
- We would be “Background-free” even with $\times 10$ better sensitivity.
- The search will be continued in E949.
(New “1gamma” trigger with the BVLinear signals)