

Several ROD

(Studies)

Lead/Scint: Calorimeter 1m
with WLSF --> Prototype

High OE
PMT

E391a Detector

Beam Catcher

PbFe,

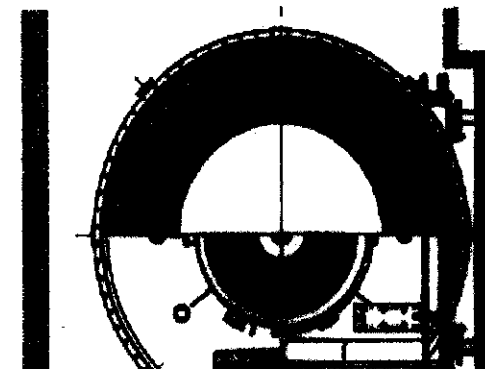
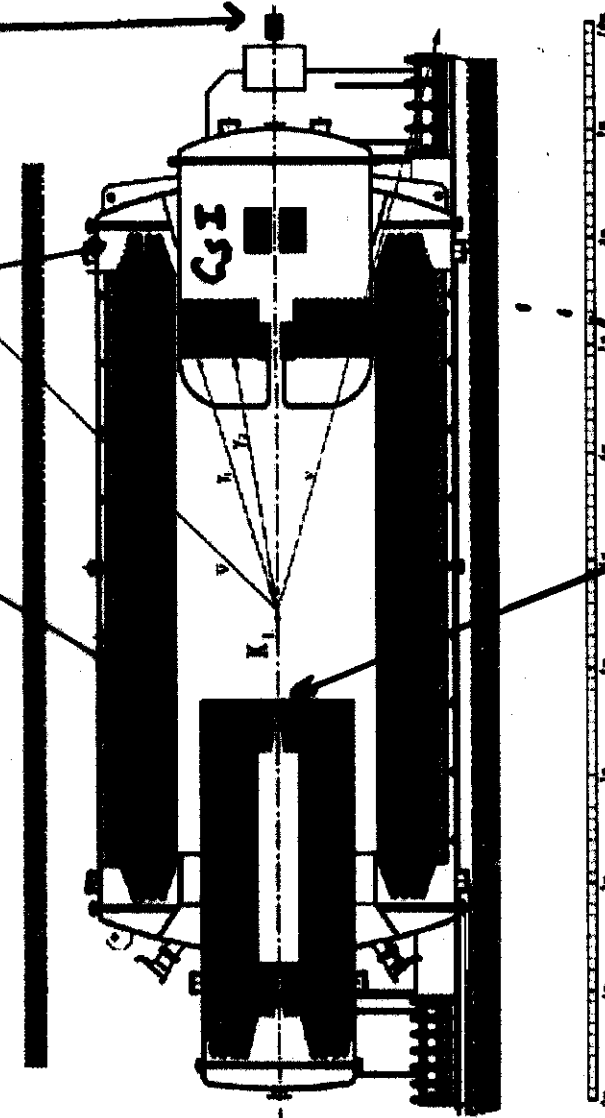
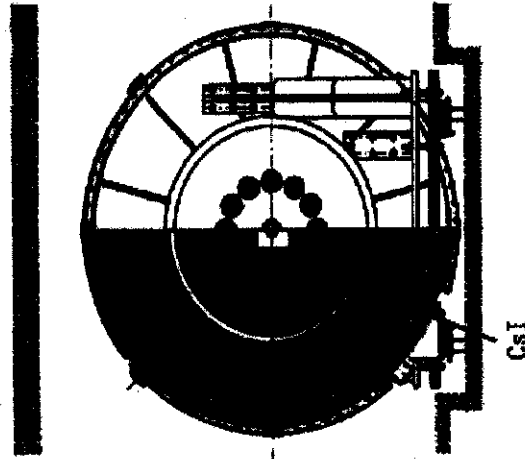

"Main Detector
in the Next Generation"

Tests for CeF₃ Crystal

Ryuichi CHIBA

Dept.Phys. Yamagata UNIV.



表1

	CeF ₃	CsI
a) Density (gr/cm ³)	6.16	4.53
Radiation Length (cm)	1.7	1.9
Moliere Radius (cm)	2.6	3.8
b) Light Yield /NaI (%)	4-5	3-4
Decay Time (ns)	5,30	10,36,> 1000
Peak Emission Wave Length (nm)	300,340	300,> 400
Refractive Index	1.68	1.8
c) Light Y. Temp.Dep.(%/°C)	0.05	-1.5
Hygroscopic	no	slight
d) Compressive Strength (dyn/cm ²)	3.1×10^9	
Young's Modulus* (dyn/cm ²)	1.1×10^{12}	$< 2 \times 10^{10}$
Thermal Expan.Coeff.** (/°C)	1.3×10^{-5}	4.8×10^{-5}
e) Thermal Neutron Cross Section (barn)	0.65	35
Internal Radioactivity*** (cps/cm ³)	< 0.03	

Crystal Characteristics

* Al : $\sim 7 \times 10^{11}$ dyn/cm², Fe : $\sim 2 \times 10^{12}$ dyn/cm².

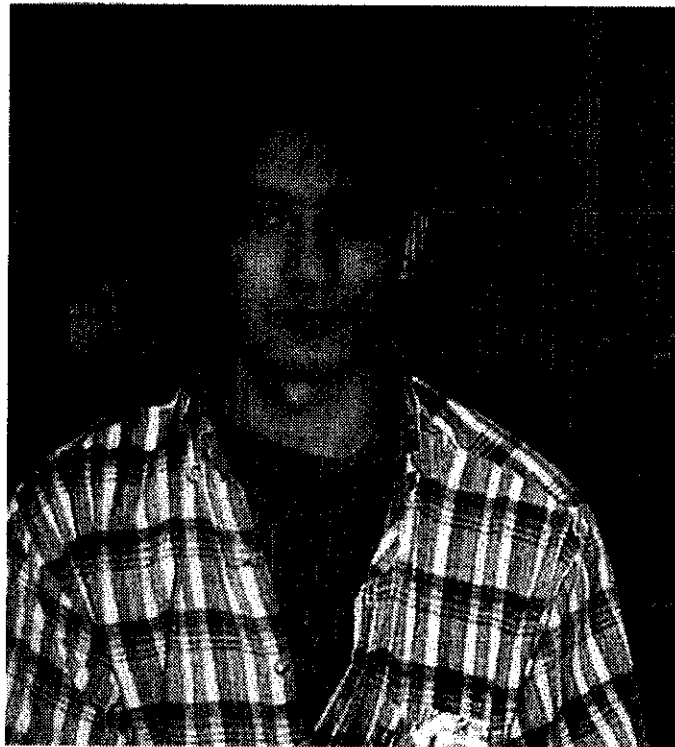
** Al : 2.3×10^{-5} /°C, Fe : 1.1×10^{-5} /°C.

*** BaF₂ : ~ 0.1 cps/cm³.

--> Main Detector
in the next high-sensitive
experiment at JHF

CeF₃ Detector

Crystal array

9	8	7
6	5	4
3	2	1

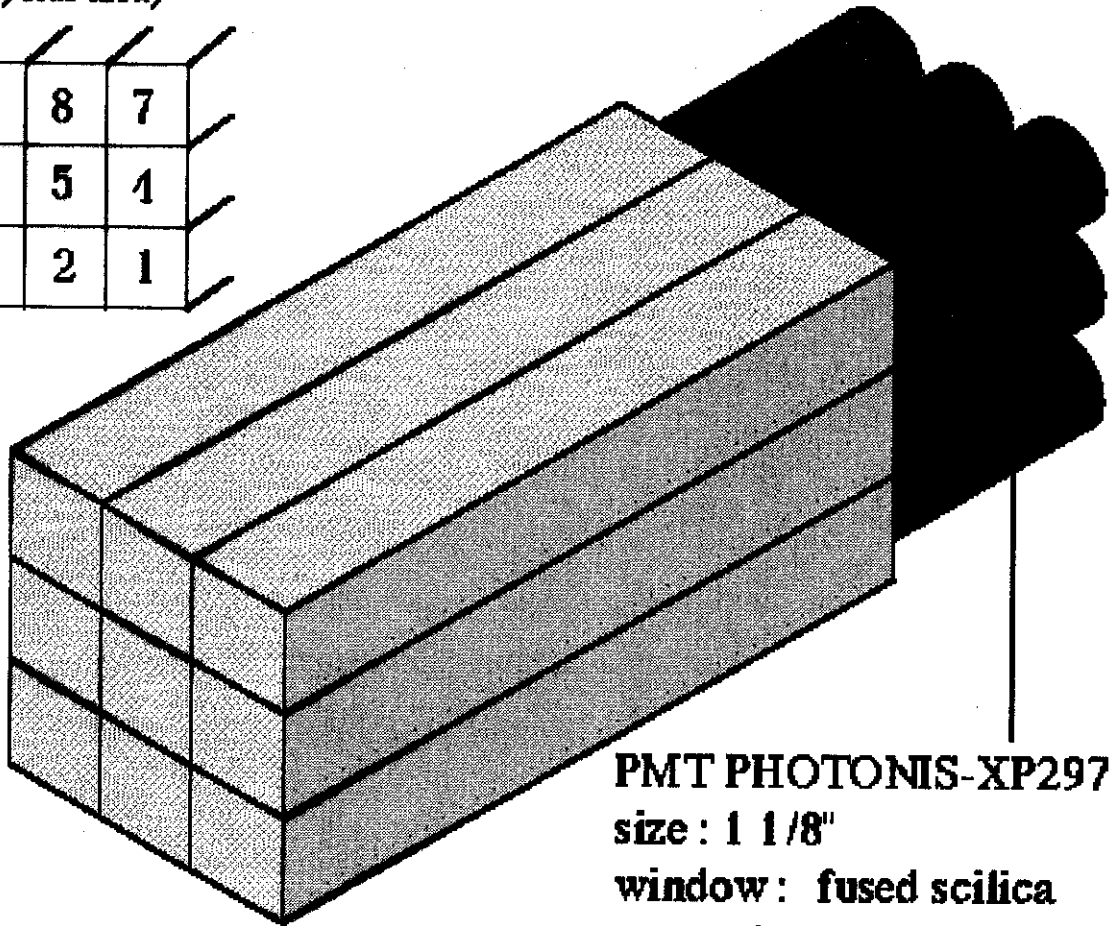

PMT PHOTONIS-XP2978
size : 1 1/8"
window : fused scilica
spectral range :
150 - 650nm

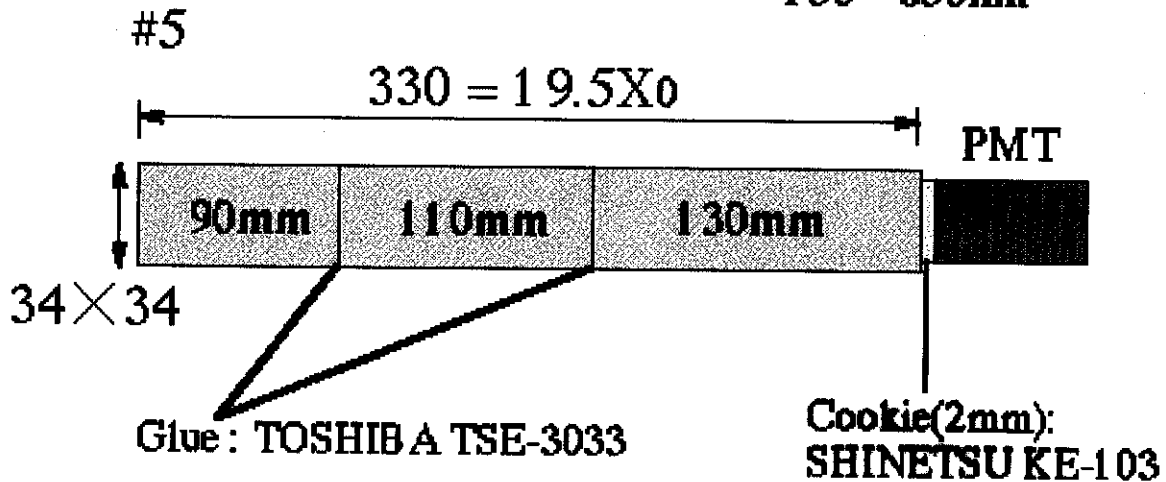

PMT Calibration

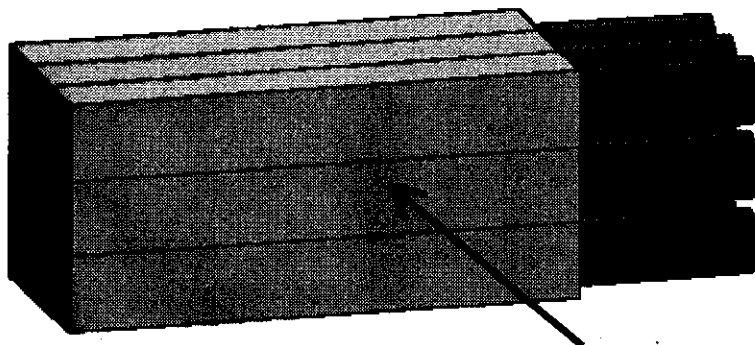

Beam 1GeV/c π^-

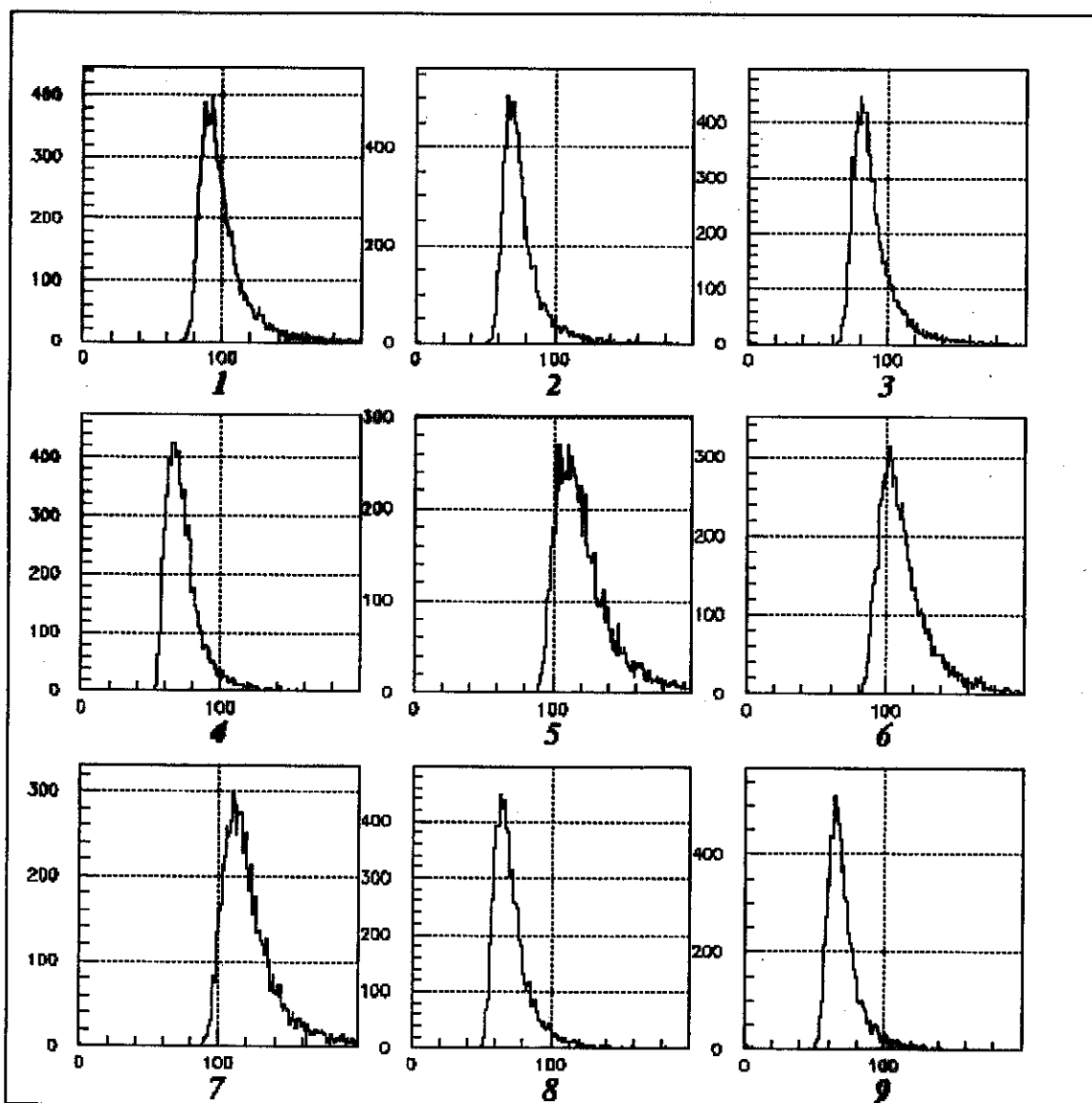

electron 1GeV/c

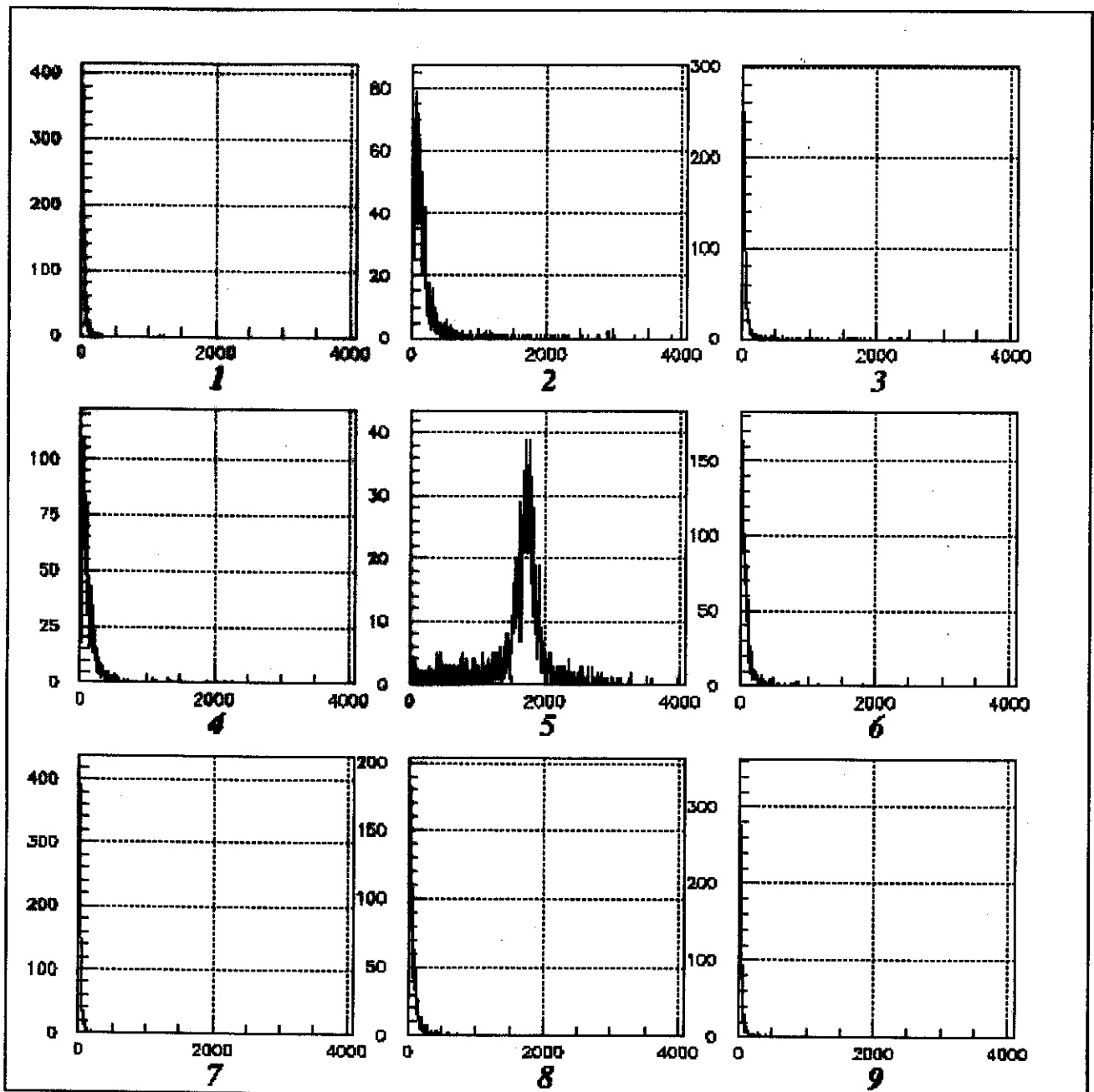

SUM
electron 1GeV/c

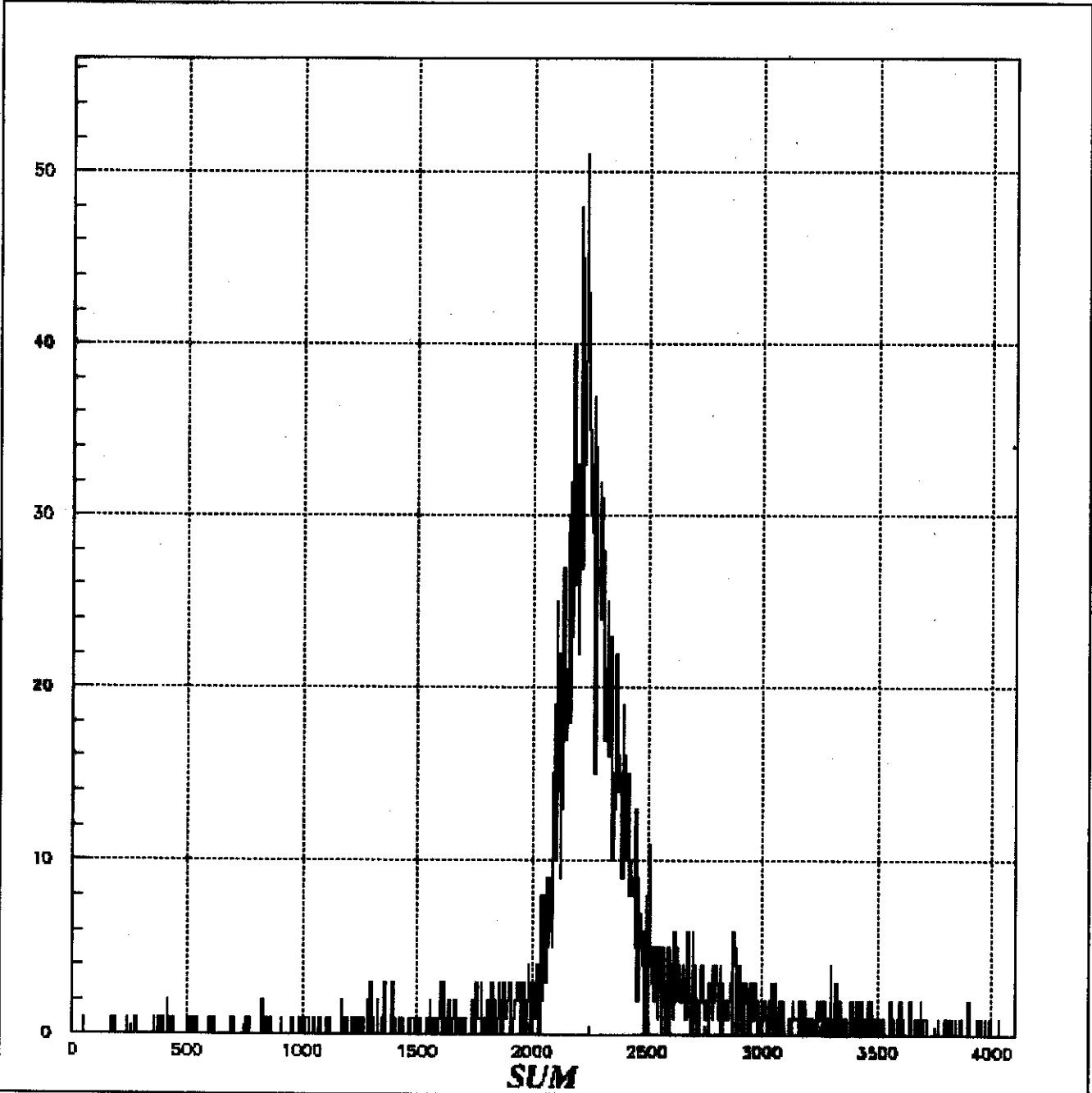

Energy resolution

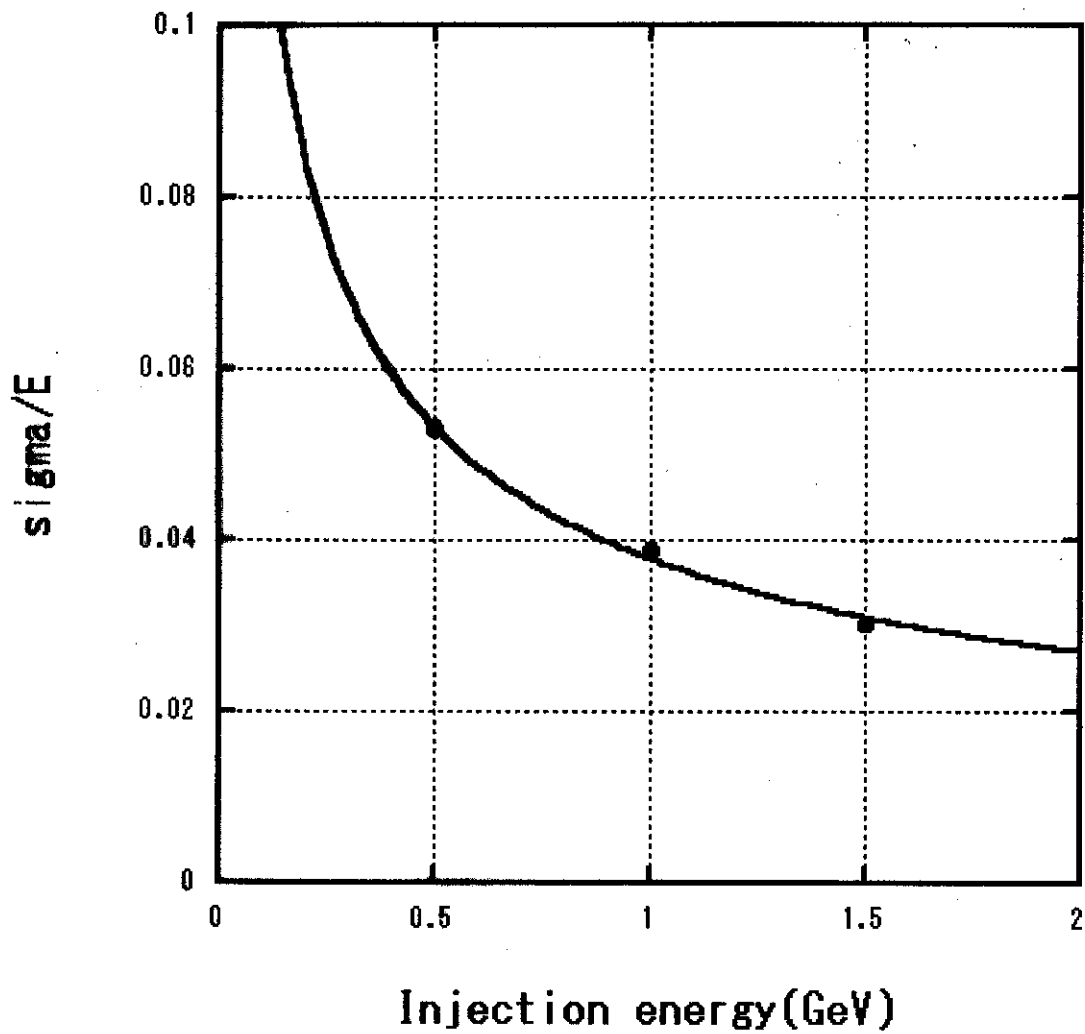

$$\frac{\sigma}{E(\text{GeV})} = \frac{(3.7 \pm 0.3) \times 10^{-2}}{\sqrt{E(\text{GeV})}} + (6.4 \pm 30.0) \times 10^{-4}$$

Linearity

