

# T1 標的とKaonビームライン

*Hitoshi Takahashi*

KEK, Institute of Particle and Nuclear Studies

Hadron Beam Line Subgroup

Target and Monitor Subgroup

- T1 Target
- Secondary Beam Lines
- Vacuum Chamber
- Maintenance Scenario

# The Only Production Target in Phase 1 of J-PARC

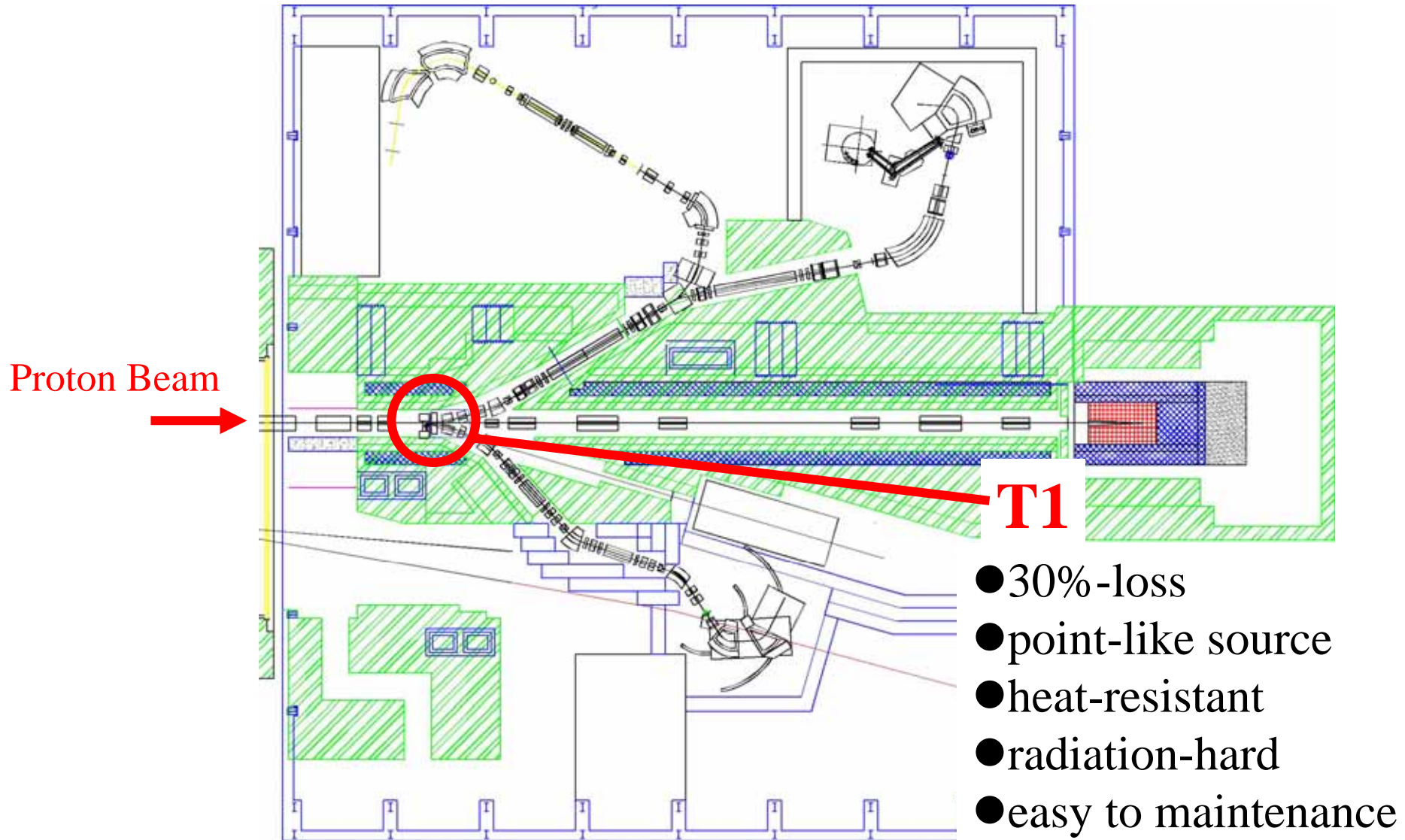

# Specifications

- made of Nickel alloy
- 280 mm $\phi$  in diameter
- total 54 mm in thickness (30% loss)
- divided to 5 disks
- 3 mm gap between the disks
- 85 rpm (1 rotation per 0.7 sec)
- direct water cooling

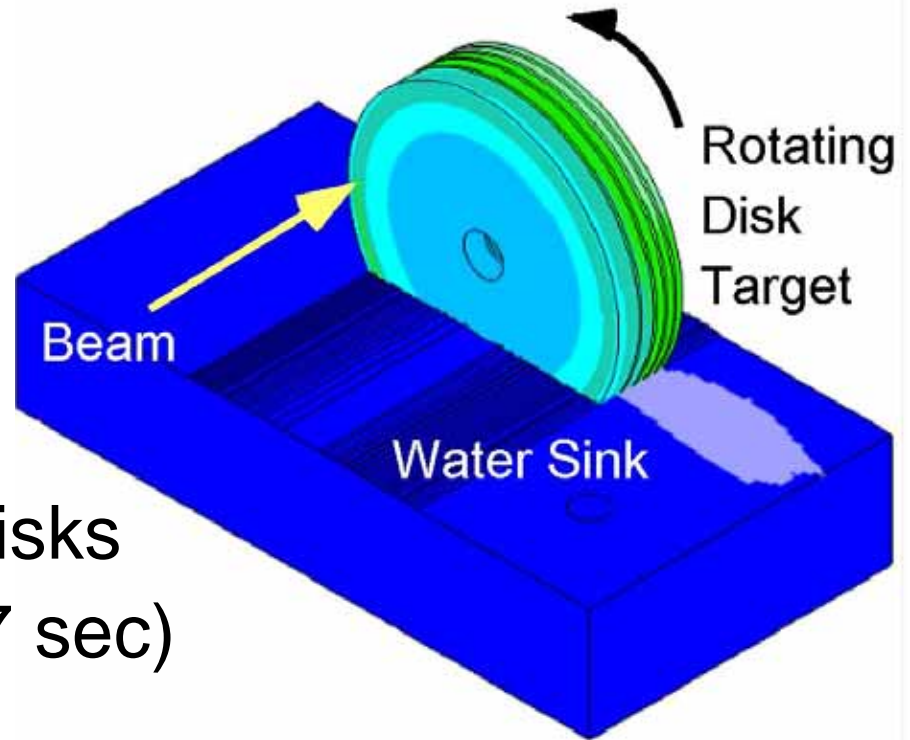

# Thermal Evolution

front view

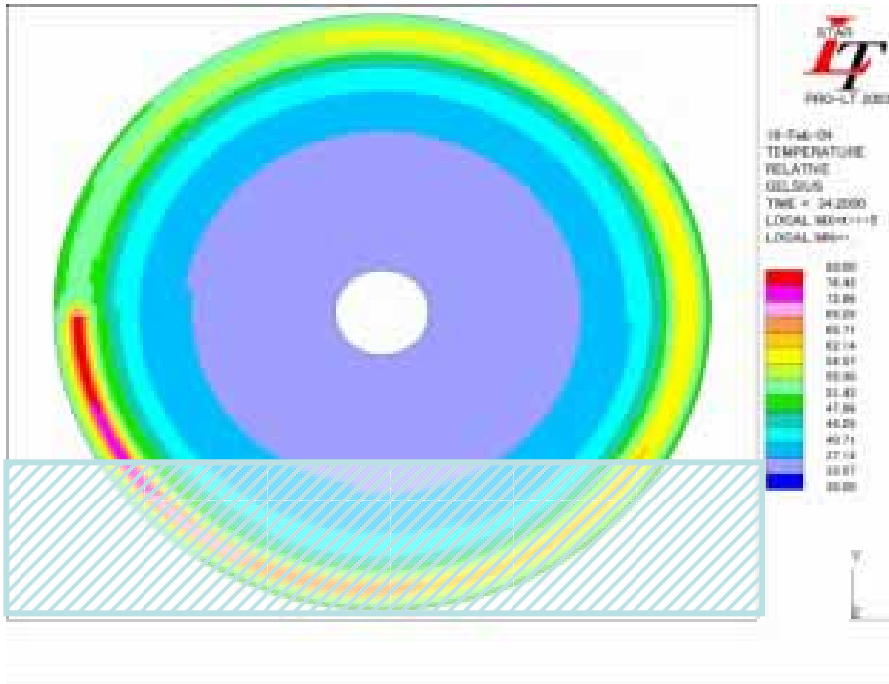

cross-sectional view

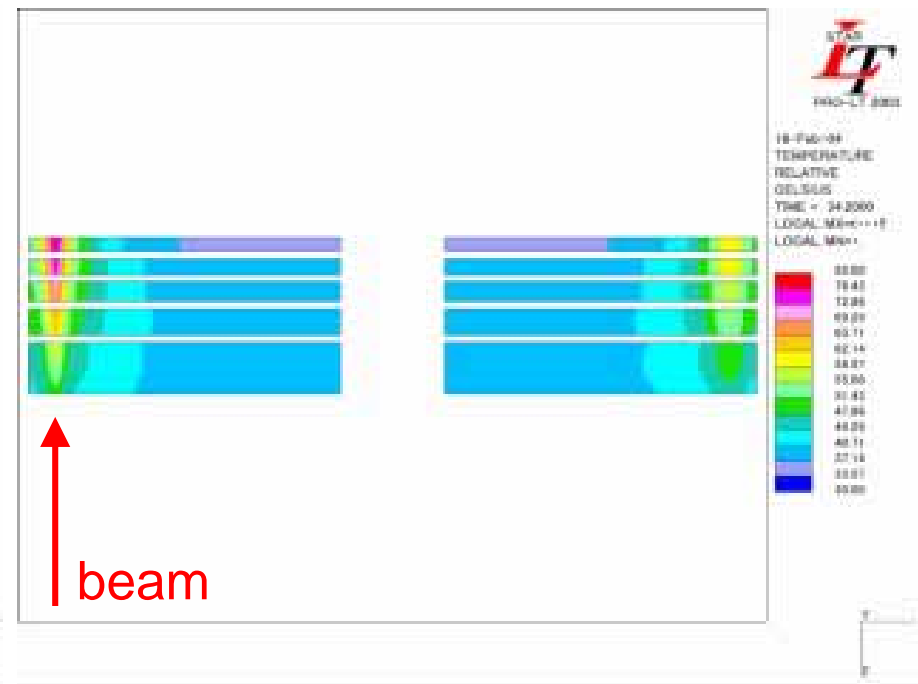

Max: about 80 °C

# T1 Target Proto Type

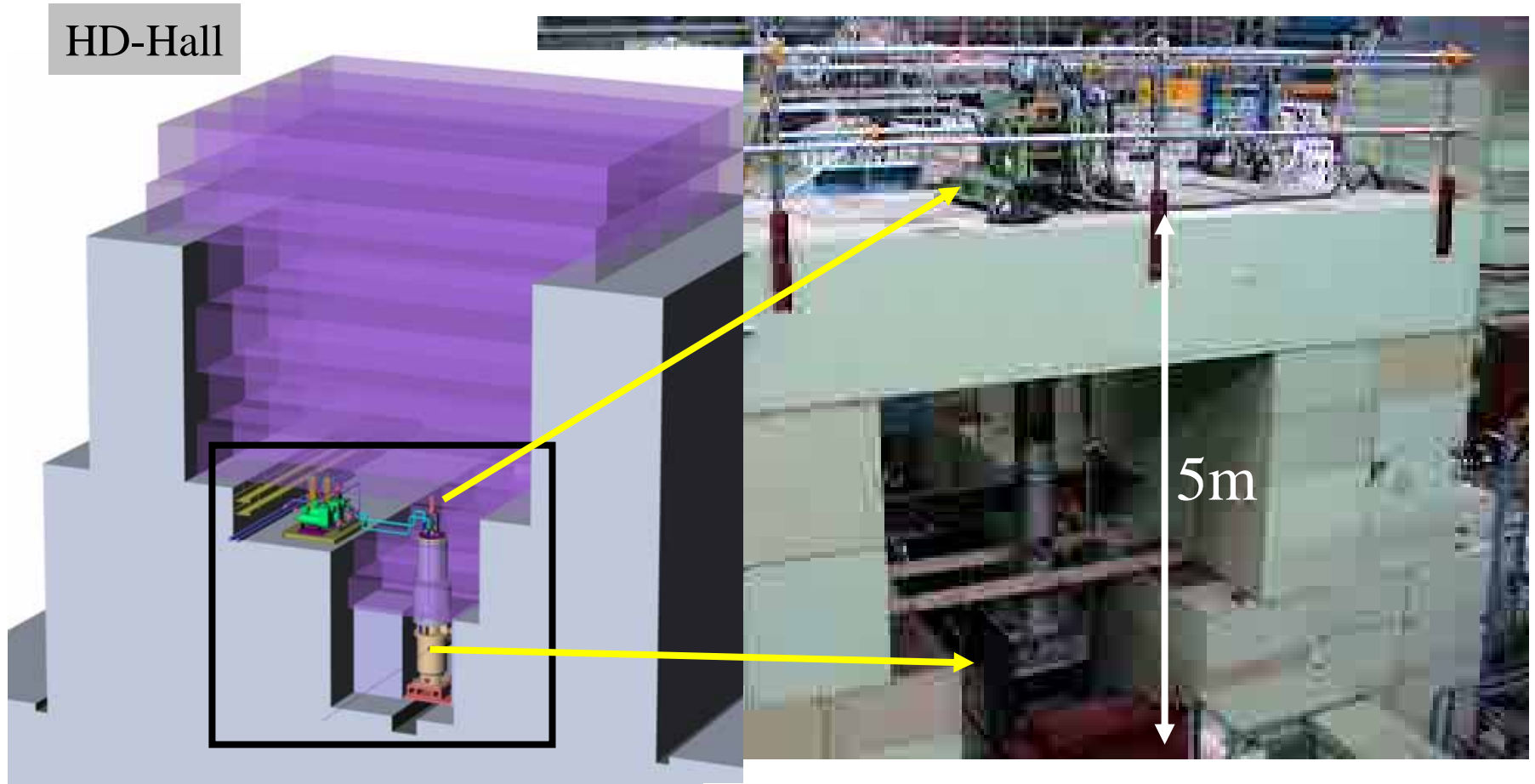

Mock-up in East Counter Hall at KEK

現在、試作2号機製作中

# Secondary Beam Lines (Phase I)

唯一の生成標的を最大限有効活用

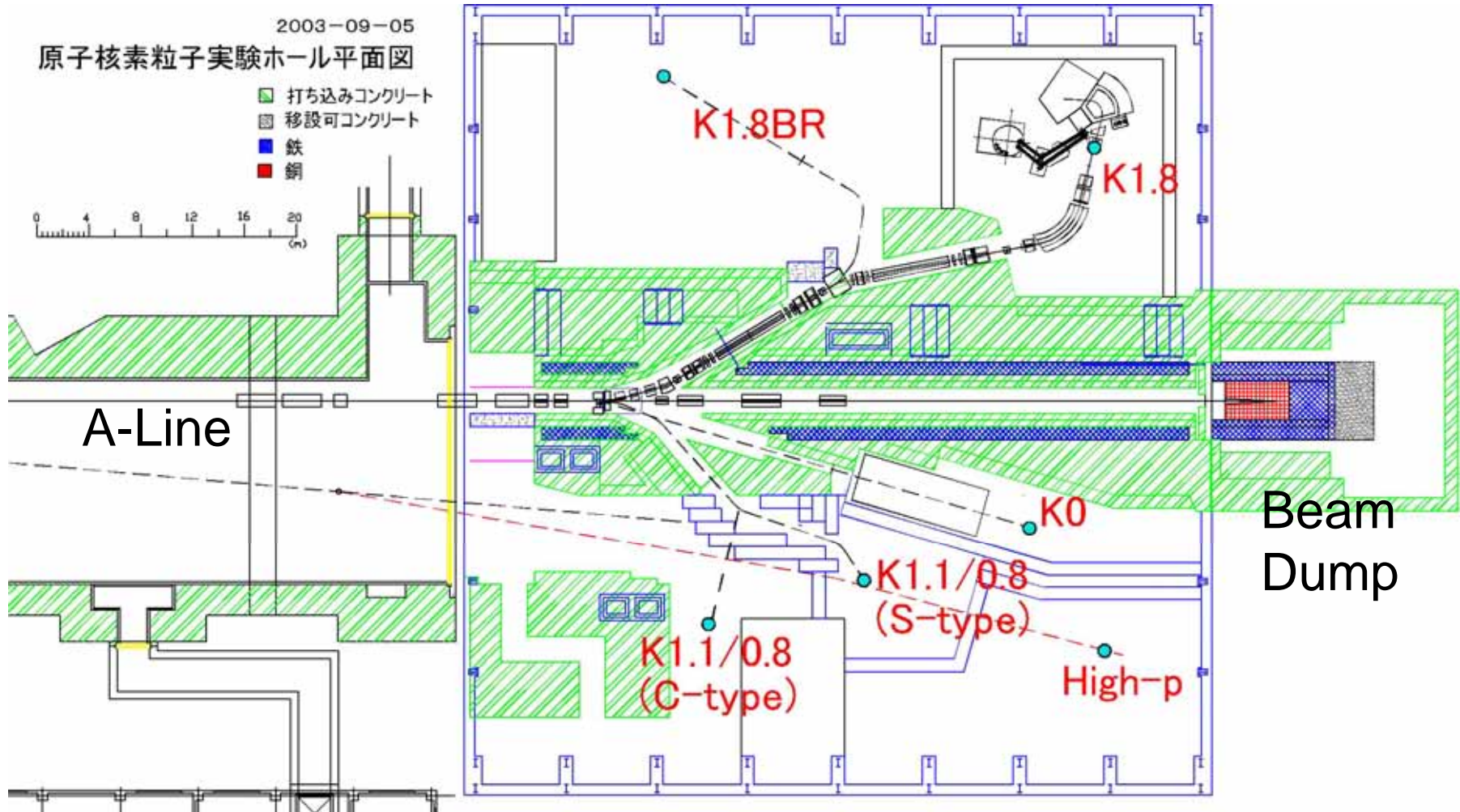

Hadron Experimental Hall (HD-Hall)

# K1.8 Beam Line

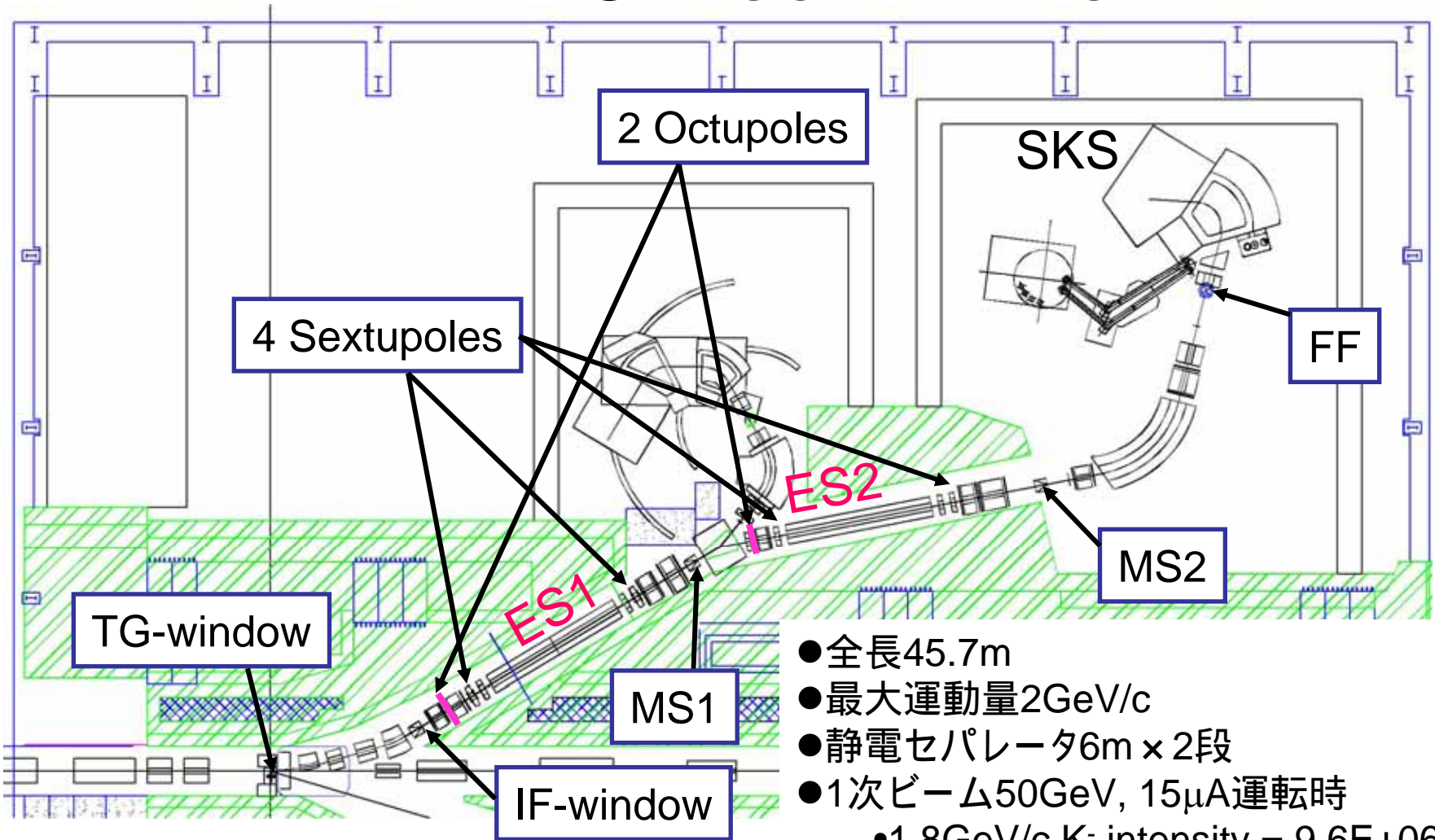

- 全長45.7m
- 最大運動量2GeV/c
- 静電セパレータ6m × 2段
- 1次ビーム50GeV, 15 $\mu$ A運転時
  - 1.8GeV/c K<sup>-</sup> intensity = 9.6E+06 ppp
  - K<sup>-</sup>/ $\pi^-$  = 2.3
- 1次ビーム30GeV, 9 $\mu$ A運転時
  - 1.8GeV/c K<sup>-</sup> intensity = 2.0E+06 ppp
  - K<sup>-</sup>/ $\pi^-$  = 2.6

MS1 opening:  $\pm 2$ mm

MS2 opening: -3.25mm,+2.75mm

using Sanford-Wang formula  
cloud  $\pi$  not included

# K1.8BR Beam Line

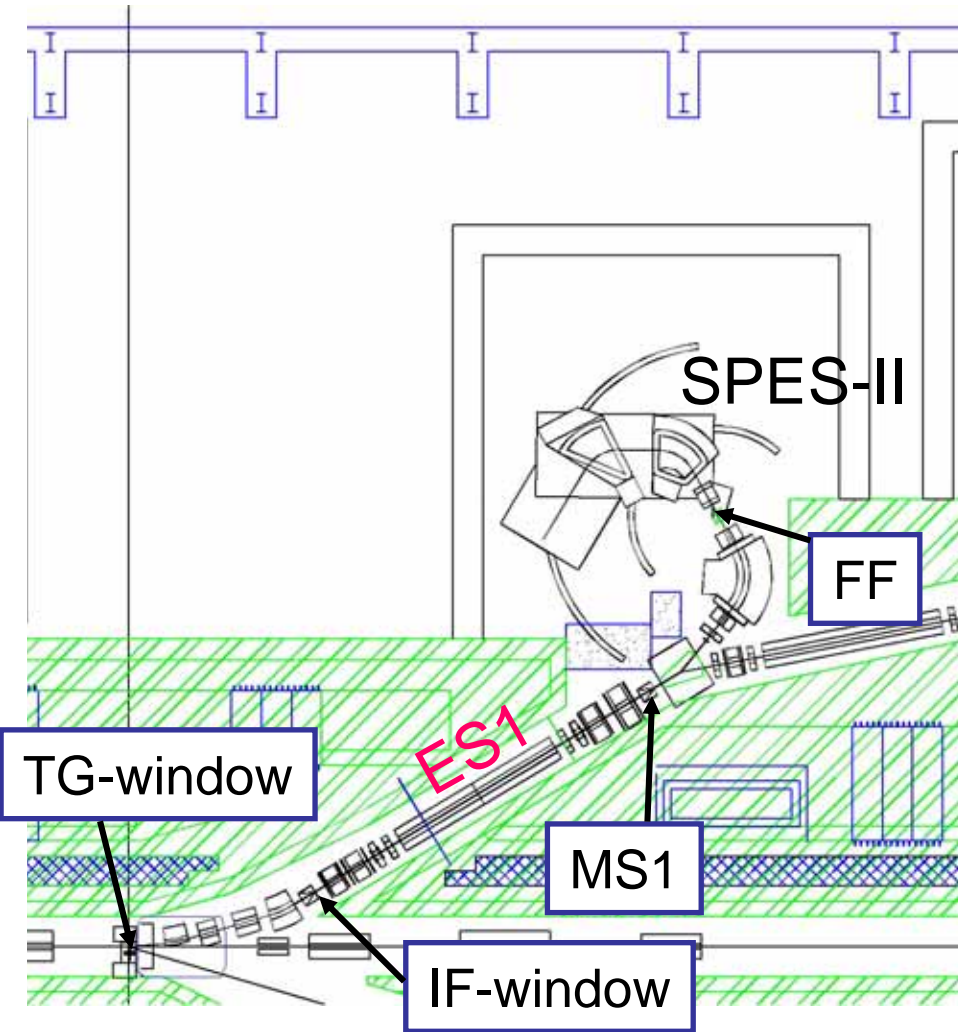

- K1.8の上流部を共有
- 全長27.0m
- 最大運動量1.2GeV/c
- 静電セパレータ6m × 1段
- 1次ビーム50GeV, 15 $\mu$ A運転時
  - 1.1GeV/c K<sup>-</sup> intensity = 10.7E+06 ppp
  - K<sup>-</sup>/ $\pi$ <sup>-</sup> = 10
- 1次ビーム30GeV, 9 $\mu$ A運転時
  - 1.1GeV/c K<sup>-</sup> intensity = 2.3E+06 ppp
  - K<sup>-</sup>/ $\pi$ <sup>-</sup> = 12

MS1 opening:  $\pm 2$ mm  
using Sanford-Wang formula  
cloud  $\pi$  not included

# K1.1/0.8 Beam Line (S-Type)

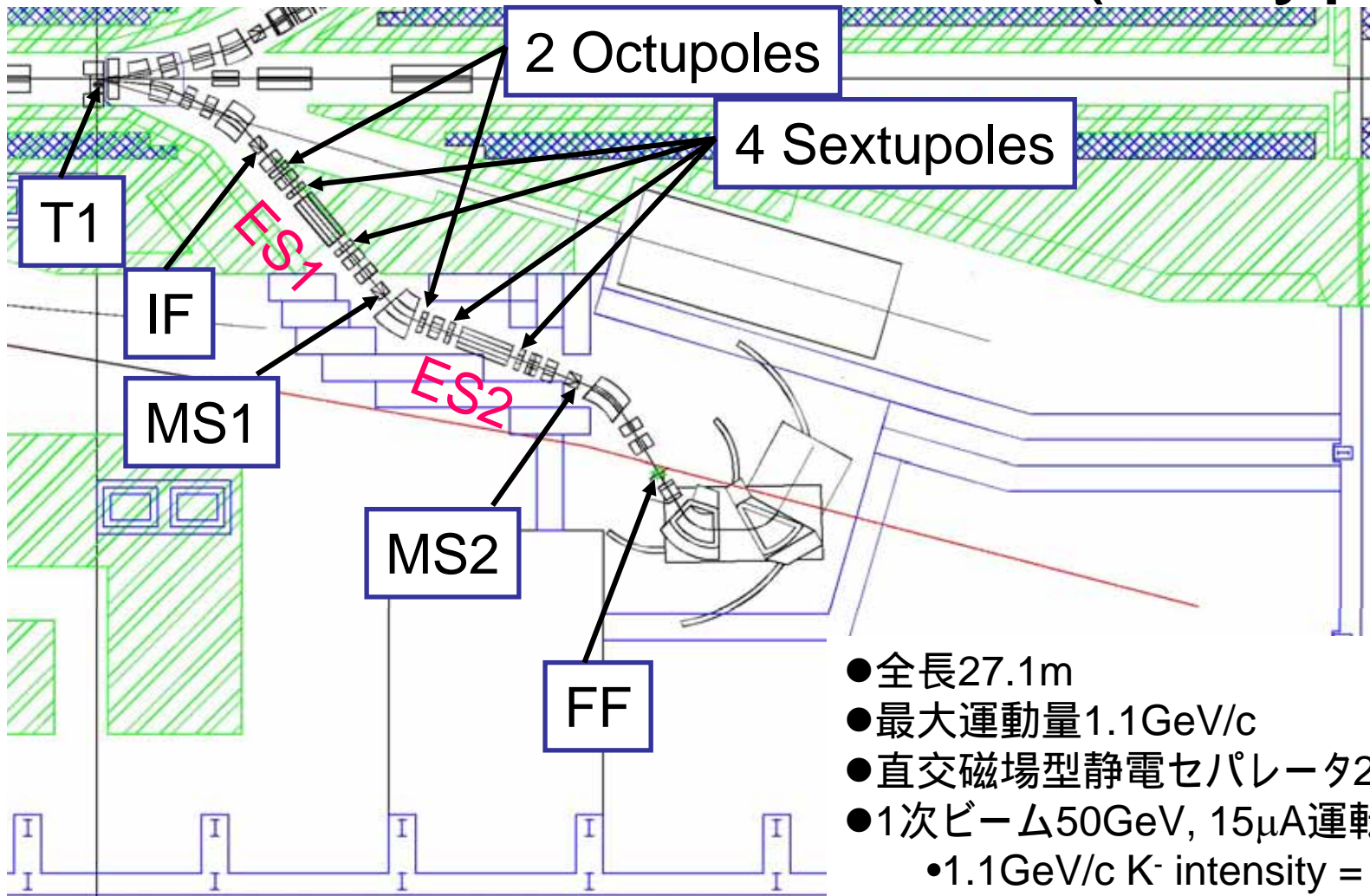

MS1 opening:  $\pm 1\text{mm}$   
MS2 opening:  $\pm 2\text{mm}$   
using Sanford-Wang formula  
cloud  $\pi$  not included

- 全長27.1m
- 最大運動量1.1GeV/c
- 直交磁場型静電セパレータ2m  $\times$  2段
- 1次ビーム50GeV, 15 $\mu$ A運転時
  - 1.1GeV/c K<sup>-</sup> intensity = 9.1E+06 ppp
  - K<sup>-</sup>/ $\pi$ <sup>-</sup> = 4.3
- 1次ビーム30GeV, 9 $\mu$ A運転時
  - 1.1GeV/c K<sup>-</sup> intensity = 2.0E+06 ppp
  - K<sup>-</sup>/ $\pi$ <sup>-</sup> = 4.7

# K1.1/0.8 Beam Line (C-Type)

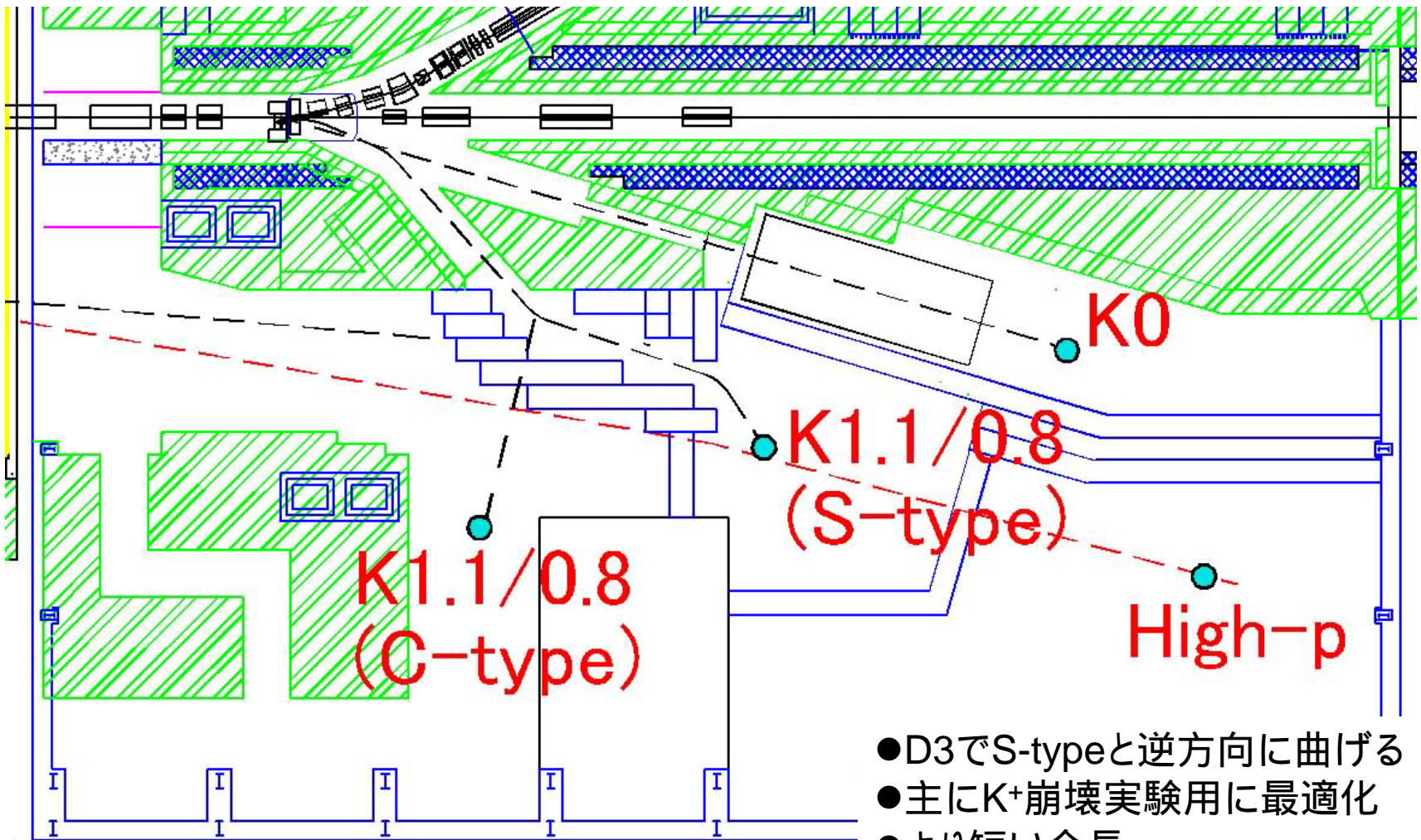

- D3でS-typeと逆方向に曲げる
- 主にK<sup>+</sup>崩壊実験用に最適化
- より短い全長
- より低い運動量
- High-p beam line と共存可能

# Optical Design with Decay TURTLE/TRANSPORT (50GeV, 15 $\mu$ A)

	K1.8	K1.8BR	K1.1/0.8
Max. Mom. (GeV/c)	2	1.2	1.1
Length (m)	45.694	26.973	27.05
Acceptance (msr.%)	2.0	4.5	4.1
K <sup>-</sup> Intensity (ppp) <sup>#</sup> 1.8 GeV/c	9.6E+06		
1.1 GeV/c	0.6E+06	10.7E+06	9.1E+06
0.8 GeV/c		2.0E+06	1.7E+06
Electro-static Separator	750kV/10cm 6m x 2	500kV/10cm 6m x 1	750kV/10cm 2m x 2
K <sup>-</sup> / $\pi$ <sup>-</sup> (cloud $\pi$ not included)	2.3 (1.8GeV/c)	10 (1.1GeV/c)	4.3 (1.1GeV/c)
Mom. Resolution (% in $\sigma$ )	0.03	0.02	-
X/Y(FWHM) size @ FF (mm)	16/8	38/7	10/6

2004.7.30

% taking 3<sup>rd</sup> order into account

# using Sanford-Wang formula, assuming 1pulse=3.53s (0.7s flat top)

# Optical Design with Decay TURTLE/TRANSPORT (30GeV, 9 $\mu$ A)

	K1.8	K1.8BR	K1.1/0.8
Max. Mom. (GeV/c)	2	1.2	1.1
Length (m)	45.694	26.973	27.05
Acceptance (msr.%)	2.0	4.5	4.1
K <sup>-</sup> Intensity (ppp) <sup>#</sup> 1.8 GeV/c	2.0E+06		
1.1 GeV/c	0.1E+06	2.3E+06	2.0E+06
0.8 GeV/c		0.44E+06	0.37E+06
Electro-static Separator	750kV/10cm 6m x 2	500kV/10cm 6m x 1	750kV/10cm 2m x 2
K <sup>-</sup> / $\pi$ <sup>-</sup> (cloud $\pi$ not included)	2.6 (1.8GeV/c)	12 (1.1GeV/c)	4.7 (1.1GeV/c)
Mom. Resolution (% in $\sigma$ )	0.03	0.02	-
X/Y(FWHM) size @ FF (mm)	16/8	38/7	10/6

2004.7.30

% taking 3<sup>rd</sup> order into account

# using Sanford-Wang formula, assuming 1pulse=3.53s (0.7s flat top)

# Downstream of T1 Target

3つの問題: 熱、放射線、磁場

How to solve 200kW Heat Problem?

**Magnets**  
**Beam Ducts**

**Upstream Collimator**  
**Big Vacuum Chamber instead of Ducts**

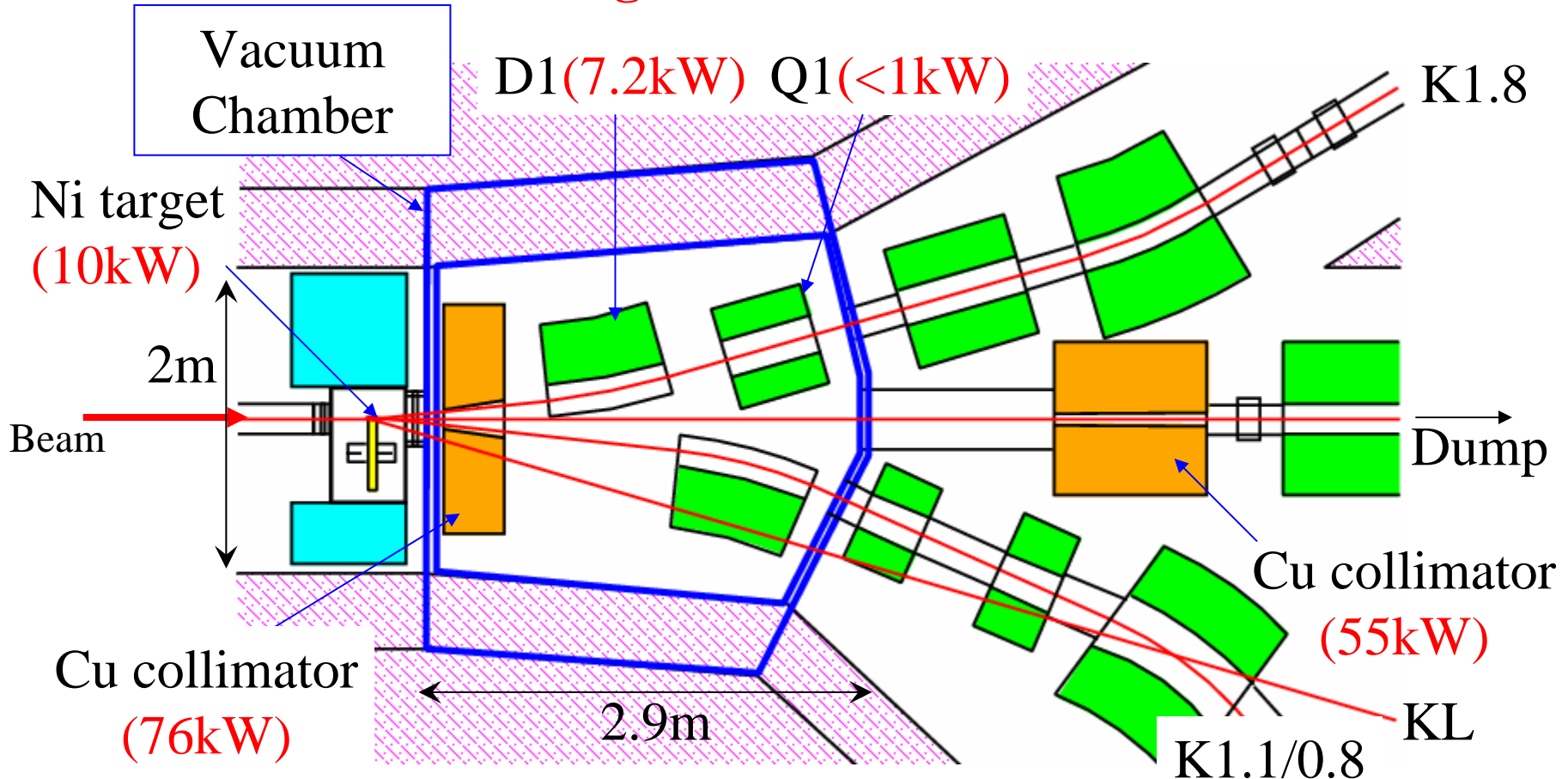

# Interference of Magnetic Field

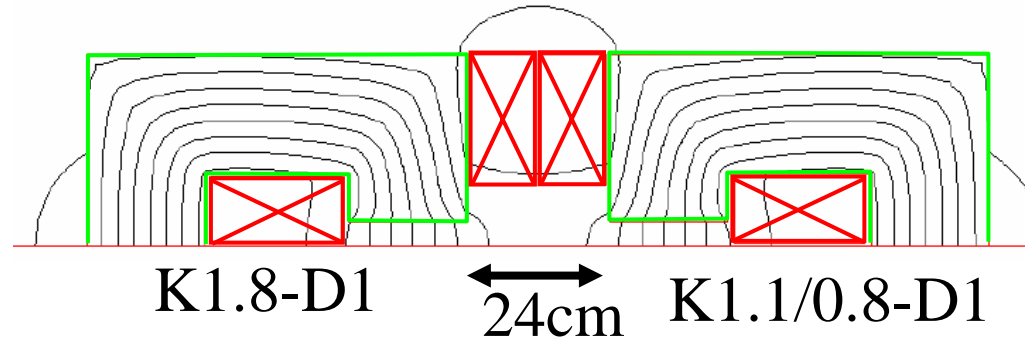
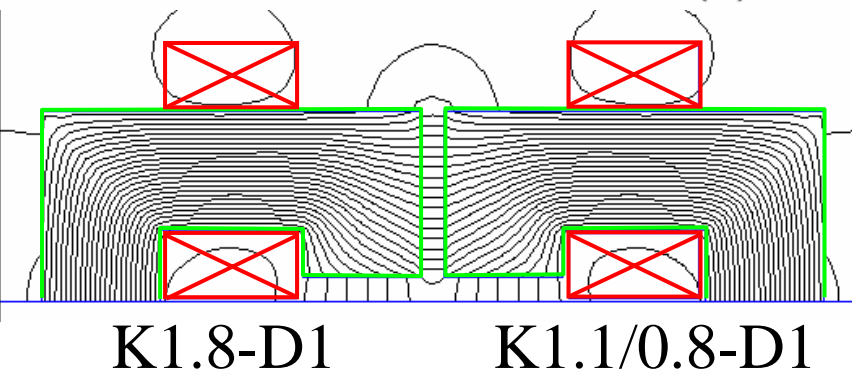
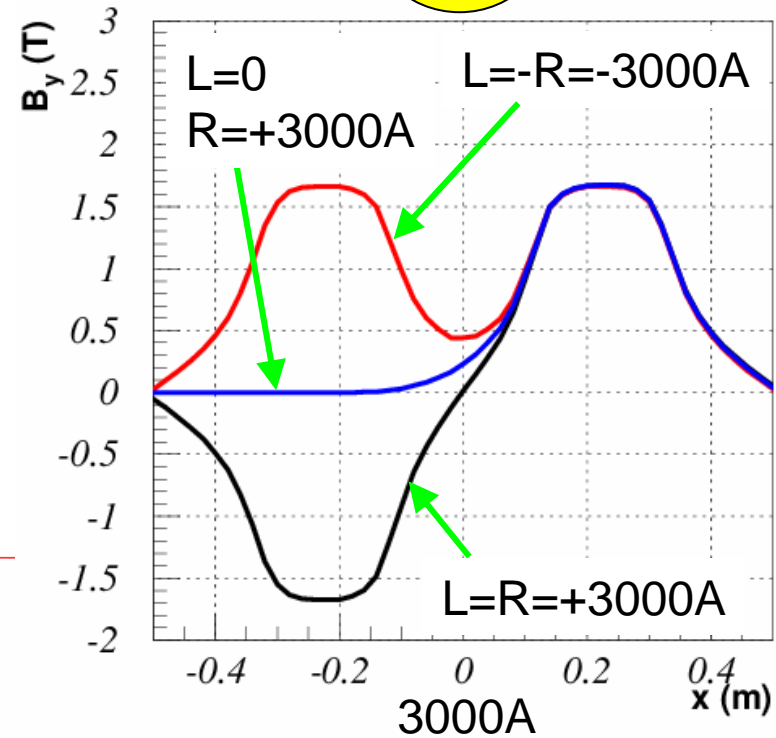
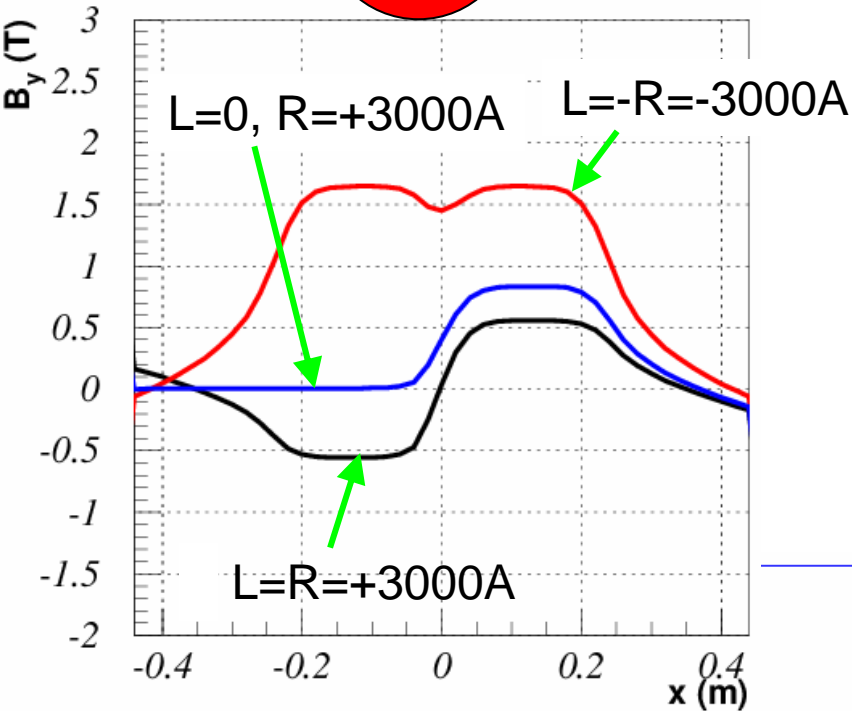
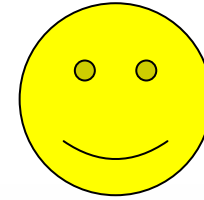

# Vacuum Chamber

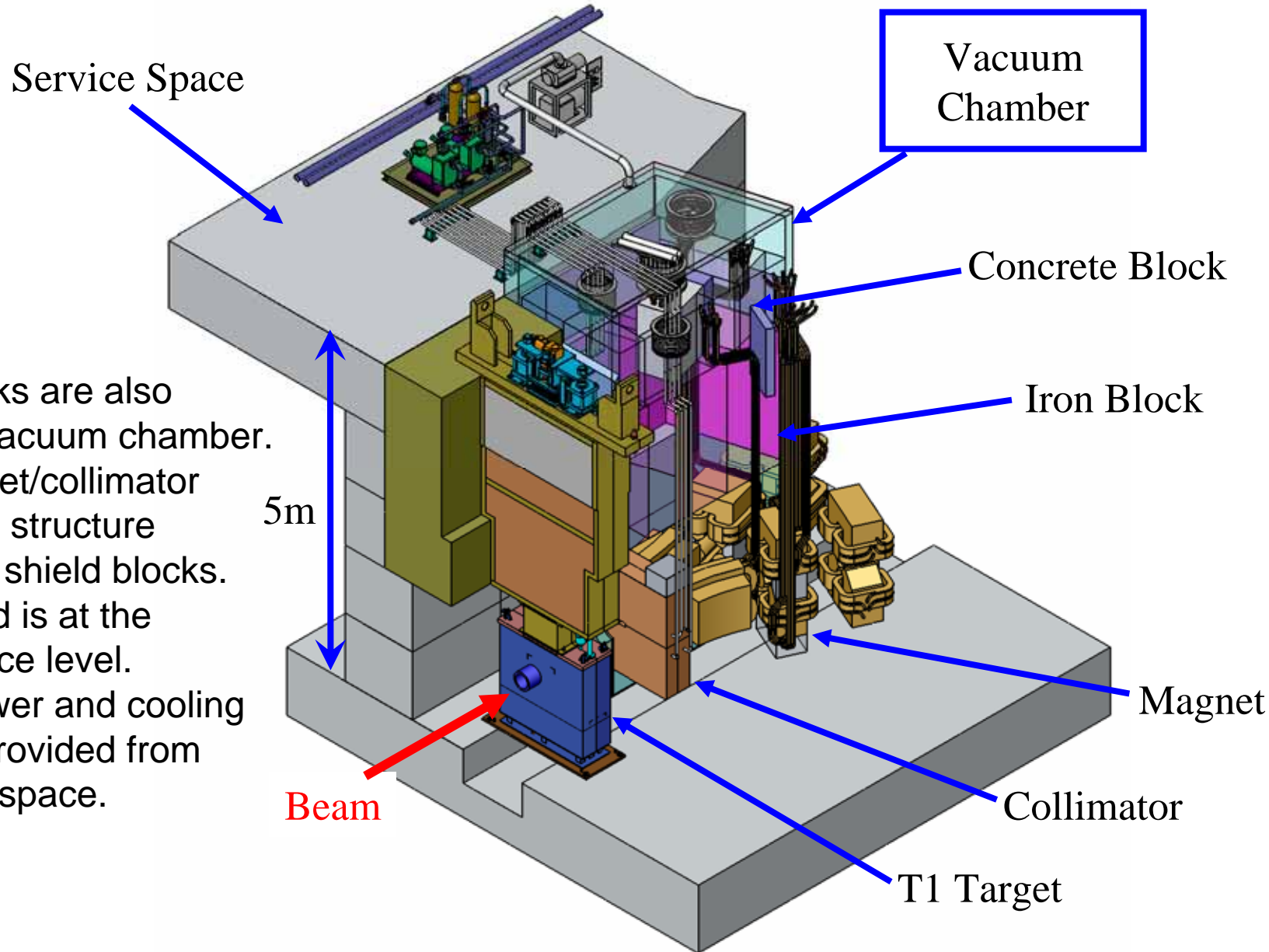

Service Space

Vacuum Chamber

Concrete Block

Iron Block

Magnet

Collimator

T1 Target

5m

Beam

- Shield blocks are also inside the vacuum chamber.
- Each magnet/collimator has module structure unified with shield blocks.
- Chamber lid is at the service space level.
- Electric power and cooling water are provided from the service space.

# Magnet in Vacuum

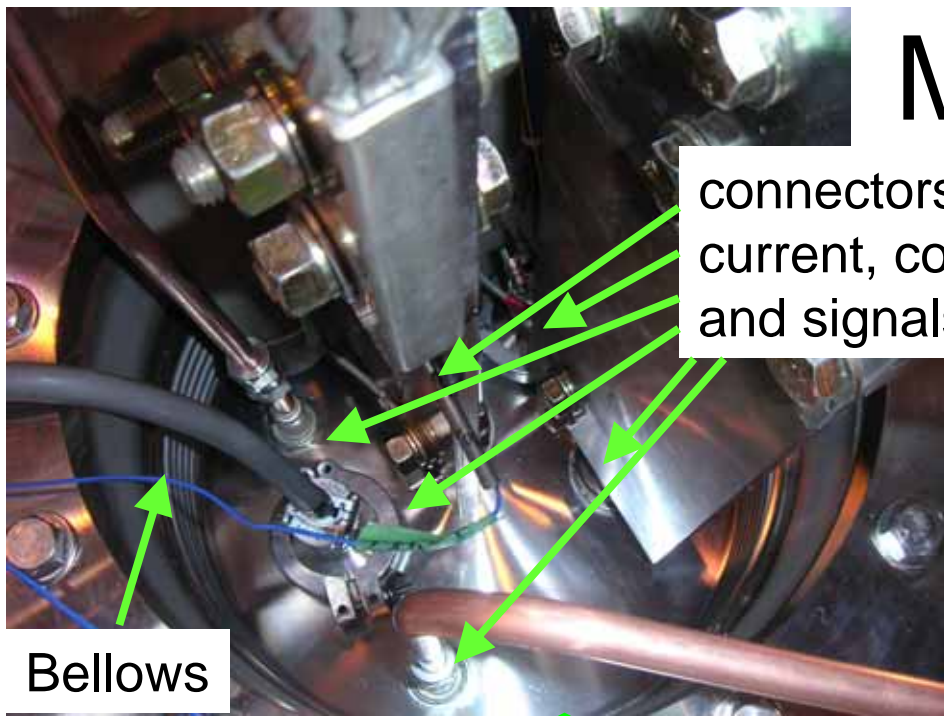

measure temperature of bus bars and hollow conductors with thermocouples

Dipole Magnet

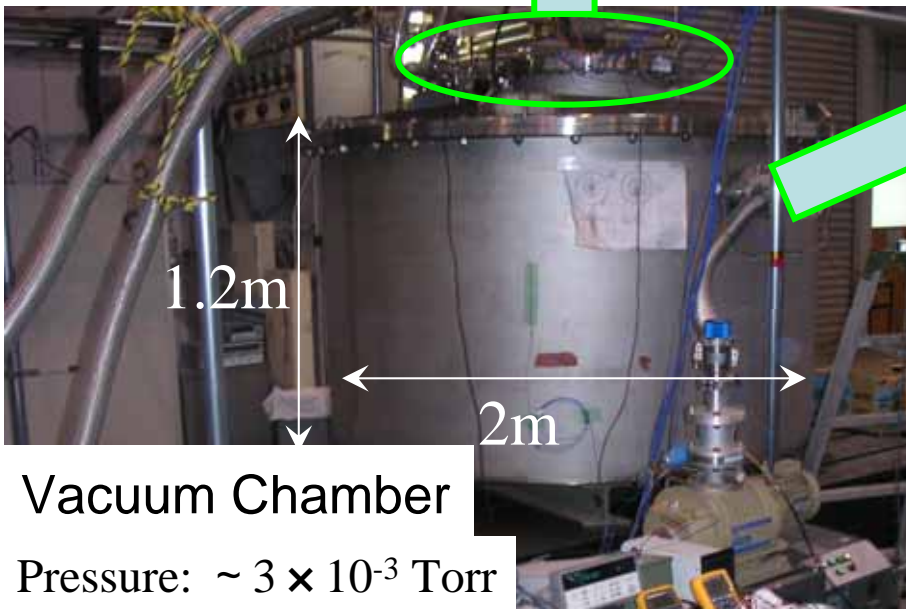
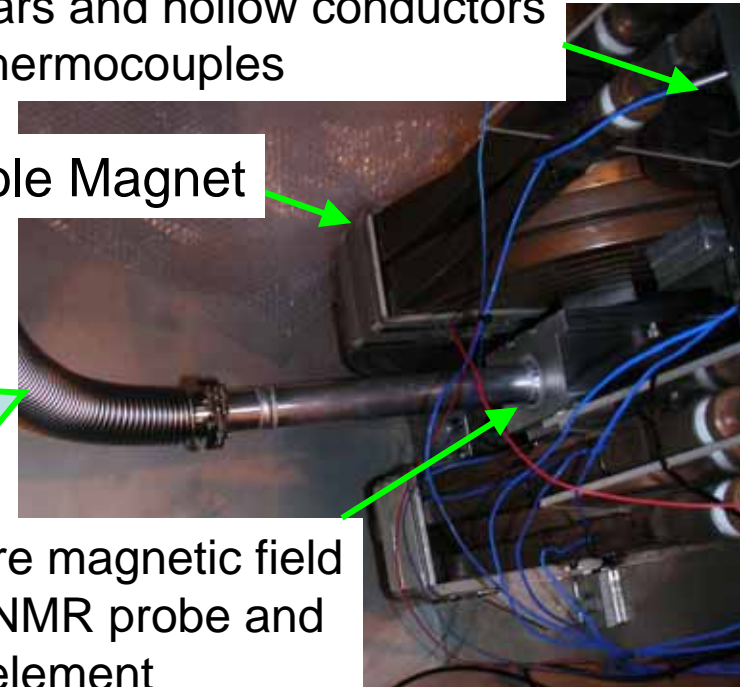

Magnet works in vacuum successfully with current of 3000A!

# Residual Dose

30日運転1日冷却後  
1年運転半年冷却後

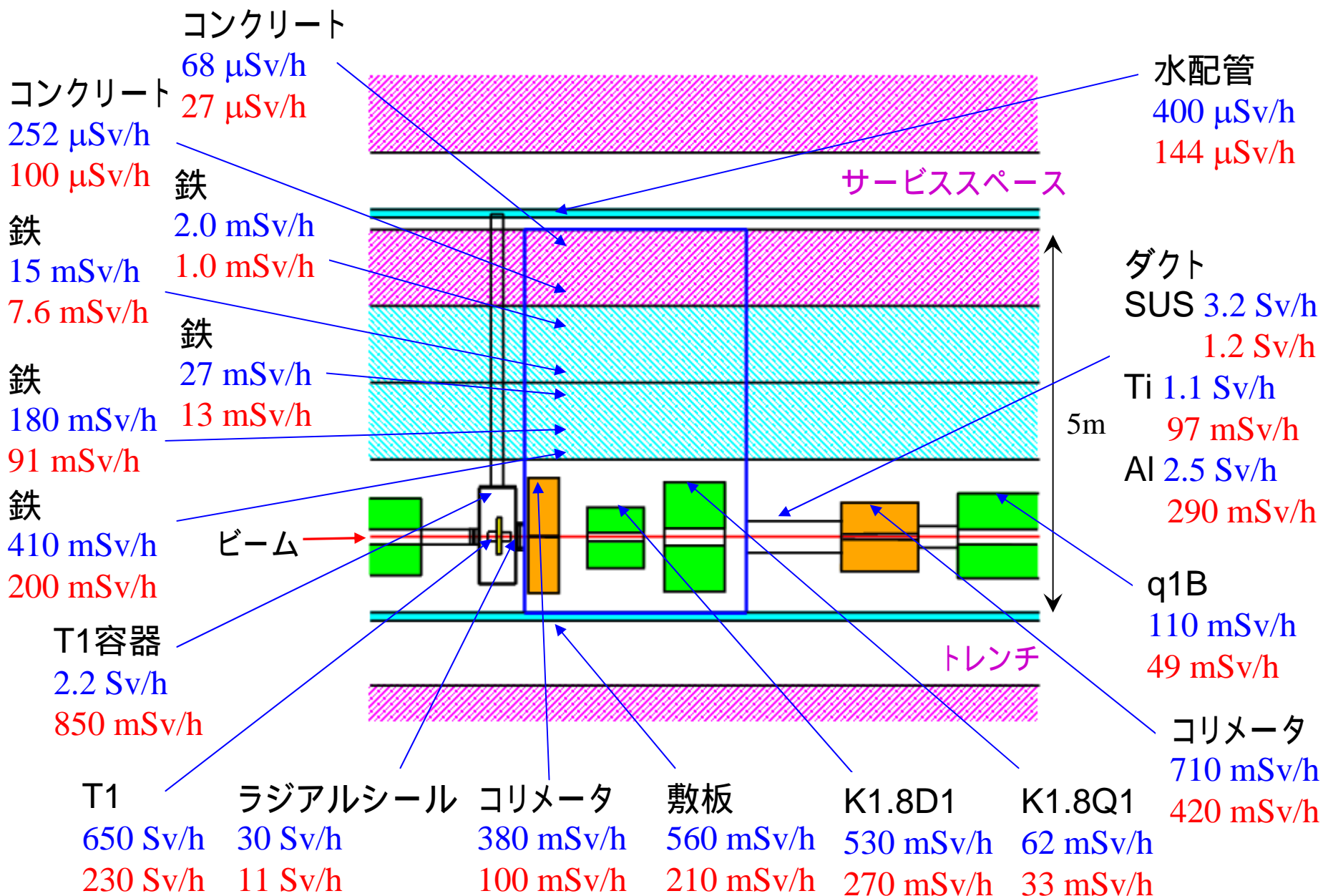

# How To Exchange Disk

1. Remove shield blocks over the target area and disconnect cables and water pipes

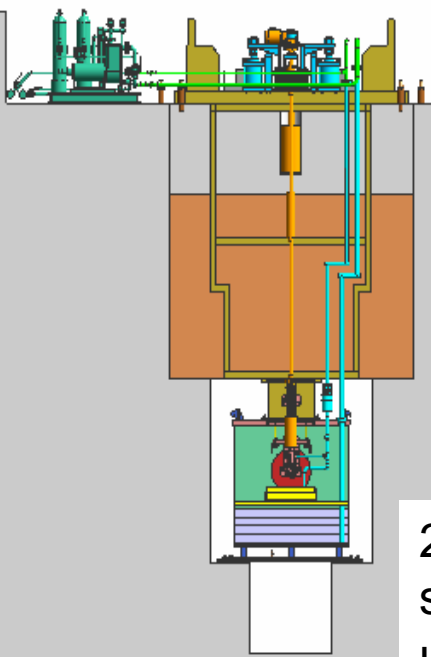

2. Remove the target shield and the driving unit using a cask

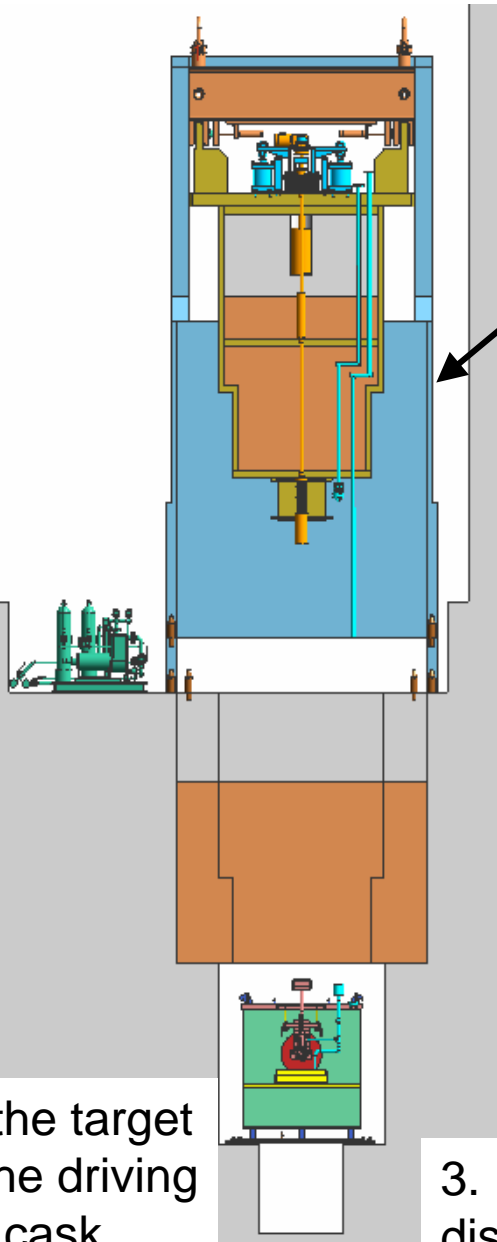

radiation-shielding cask

3. Remove the target disk using a cask

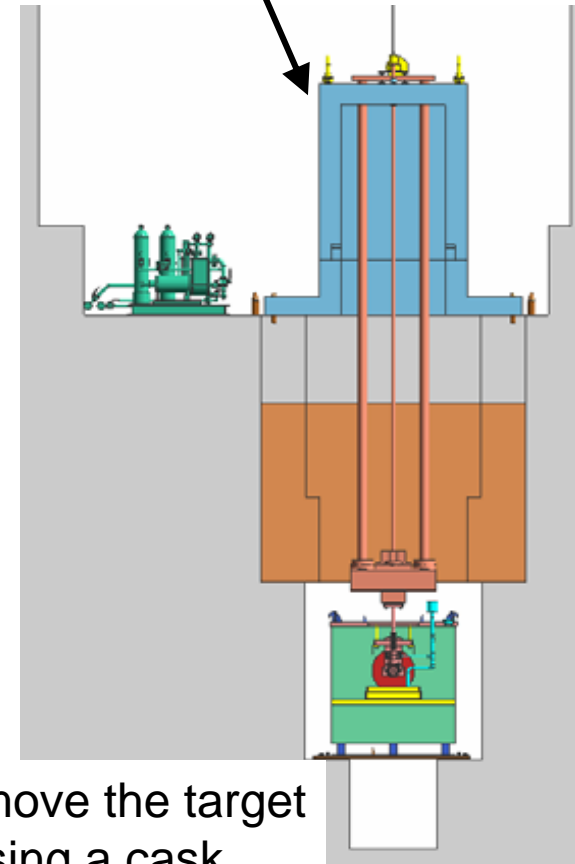

# Alignment Test with Dummy Cask



Magnet module  
proto-type



Dummy cask

# Summary

- T1: 直接水冷式回転Niディスク標的
- 唯一の生成標的を最大限活用
  - T1から複数の2次ビームライン (K1.8, K1.8BR, K1.1/0.8, KL)
- T1直下流の熱問題      真空箱
- T1周辺の残留放射能      メンテナンスシナリオ、R&D
- ToDo
  - T1試作2号機の製作
  - 最上流部電磁石の設計
  - 真空箱の詳細設計(内部構造、強度解析、熱解析、、、)
  - 真空箱モックアップ(蓋構造)の製作