

J-PARC Neutrino Facility Status

T.Kobayashi
IPNS, KEK

T2K (Tokai to Kamioka)

LBL ν experiment

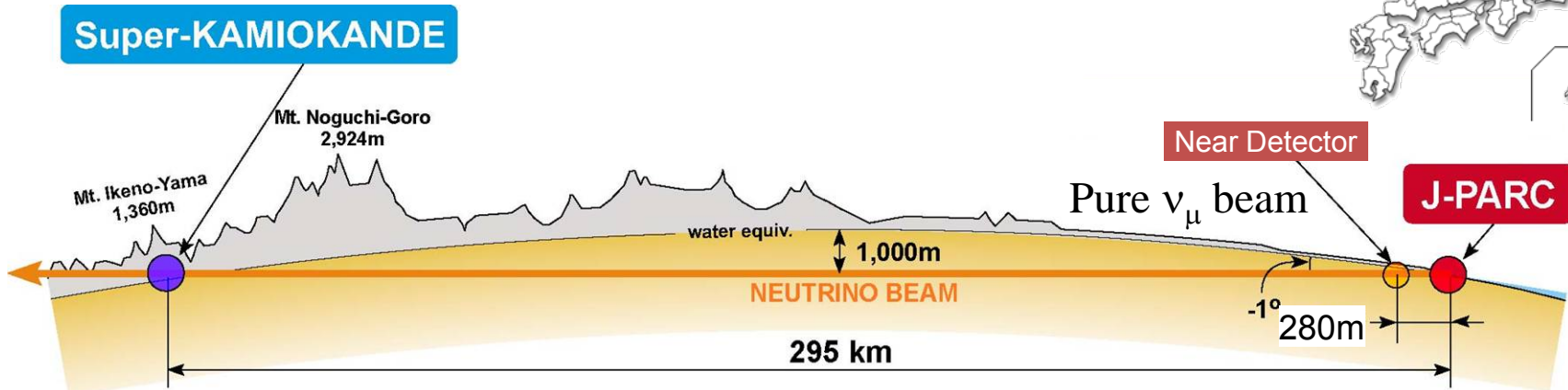
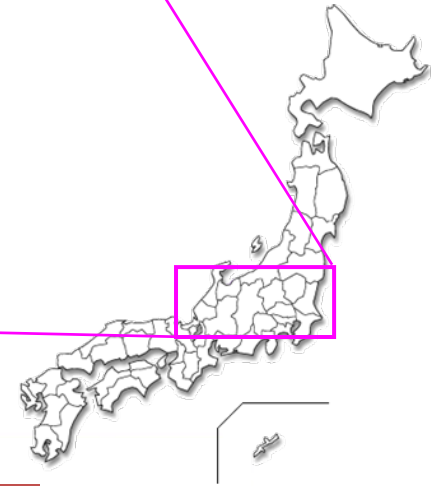
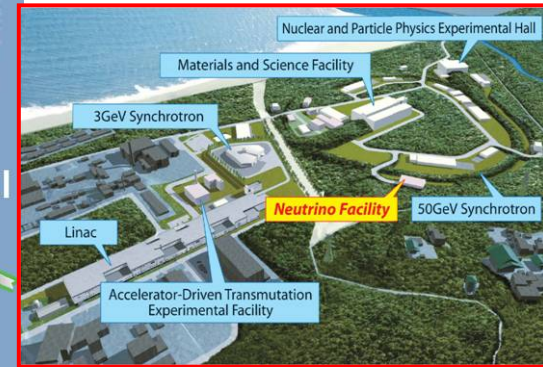
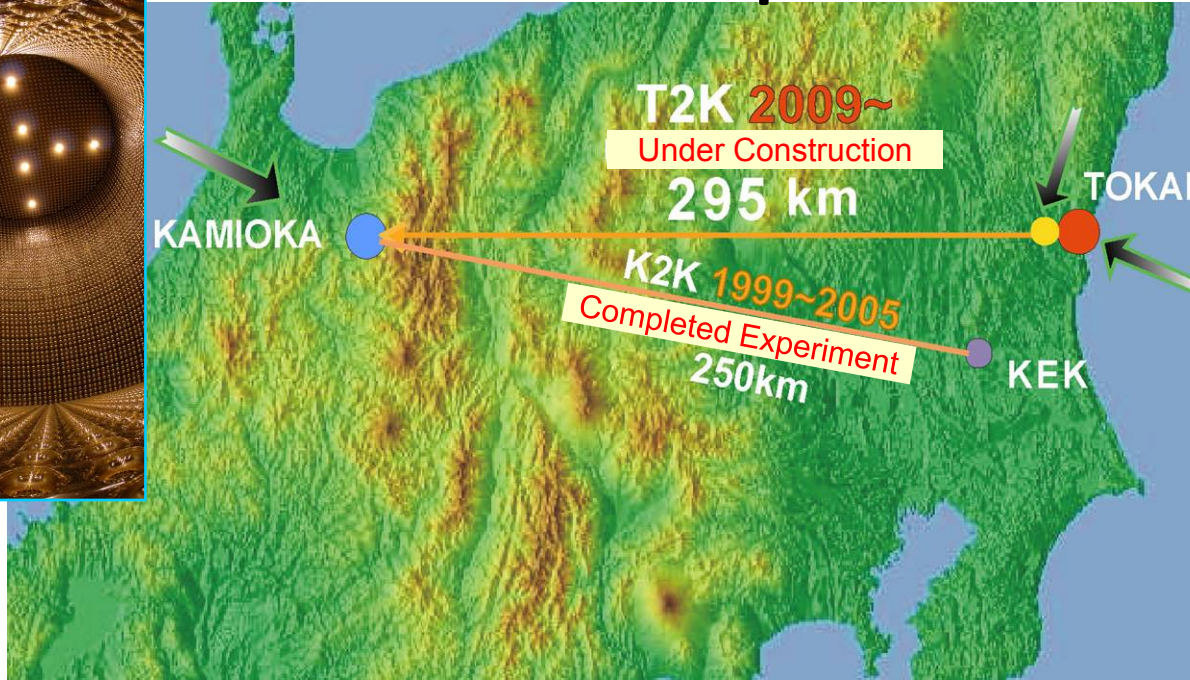
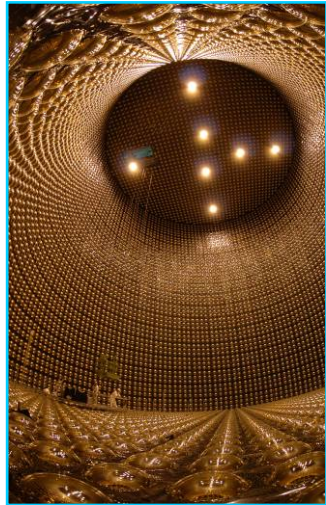

J-PARC

World Highest Intensity (\sim MW) proton accelerator facility
@ JAEA. **Construction 2001~2008**

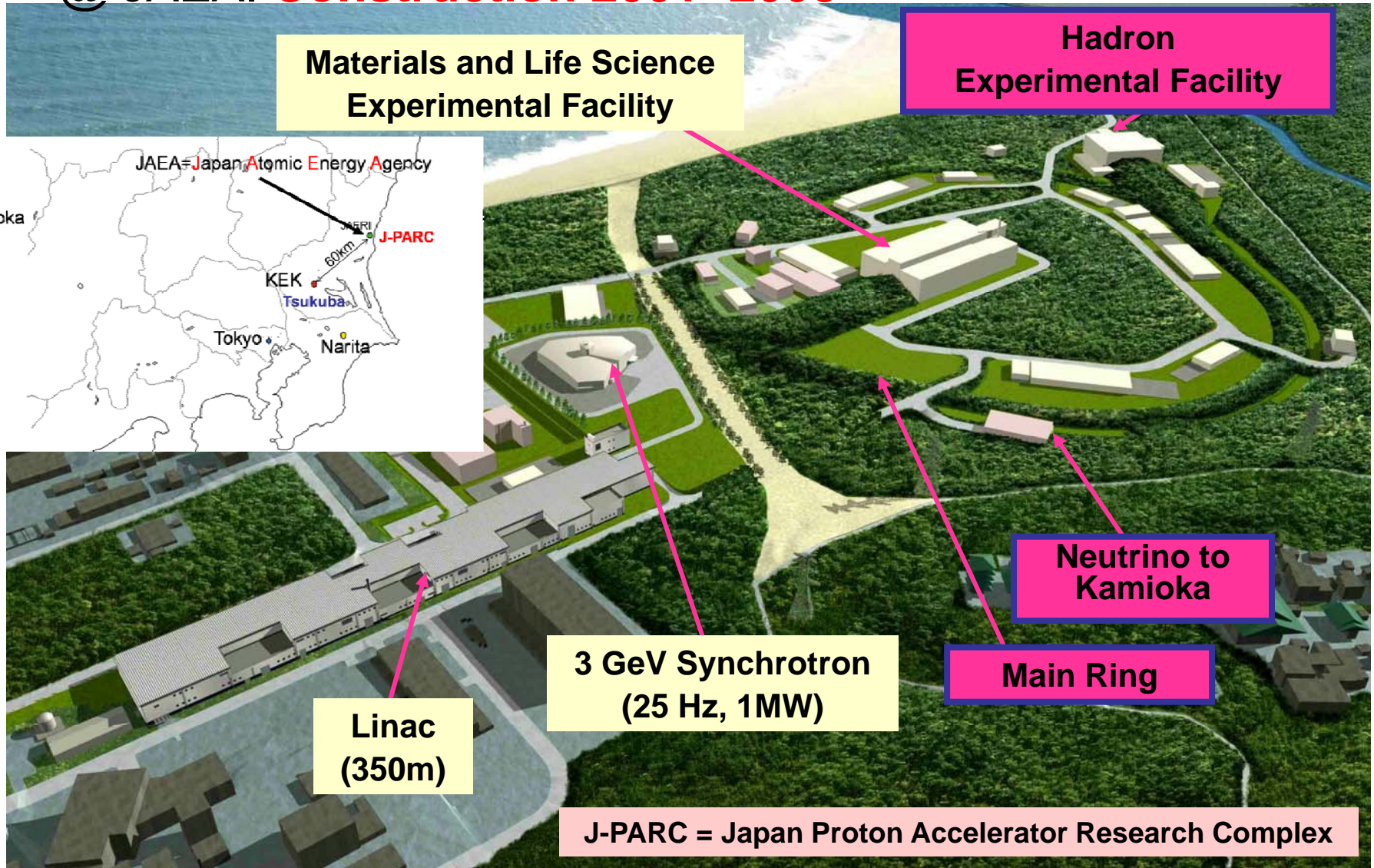

Neutrino Beam from J-PARC

- Proton beam
 - 30GeV at Day1
 - Single turn fast extraction, ~ 3 ($\rightarrow 2$) sec cycle
 - 3.3×10^{14} ppp (design)
 - \rightarrow 450kW @ 30GeV, 400MeV Linac (Design)
 - 8 bunch/pulse (design), 6 bunch at Day1
 - $\sim 4.3 \mu\text{s}$ bunch width w/ 8 bunchs
- Neutrino beam
 - 3-stage horn focused conventional beam
 - First application of off-axis beam
 - Off-axis angle 2 \sim 2.5deg. 2.5 deg at Day1
 - Can accept future higher power beam

The Neutrino Facility in J-PARC

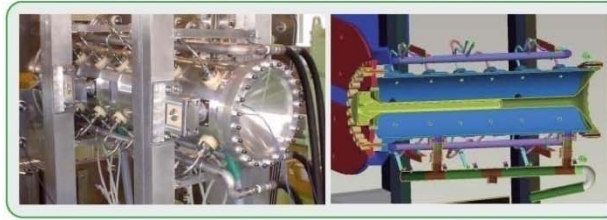

Target-Horn System

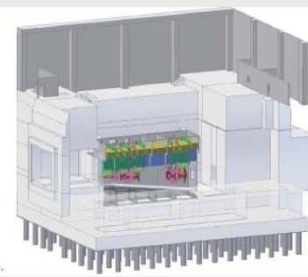

Target Station



Preparation Section

Muon Monitoring Pit

295km to
Super-Kamiokande

Final Focusing Section

110m

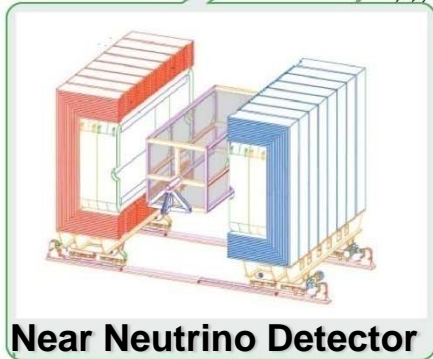

Near Neutrino Detector



Beam Dump



Decay Volume



SC combined func mags

Construction: Apr. 2004 ~ Mar. 2009 (5yrs)

Off-axis beam

First Application
(ref.: BNL-E889 Proposal)

Super-K.

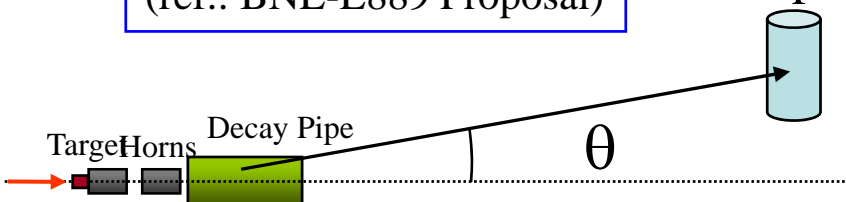

π decay Kinematics

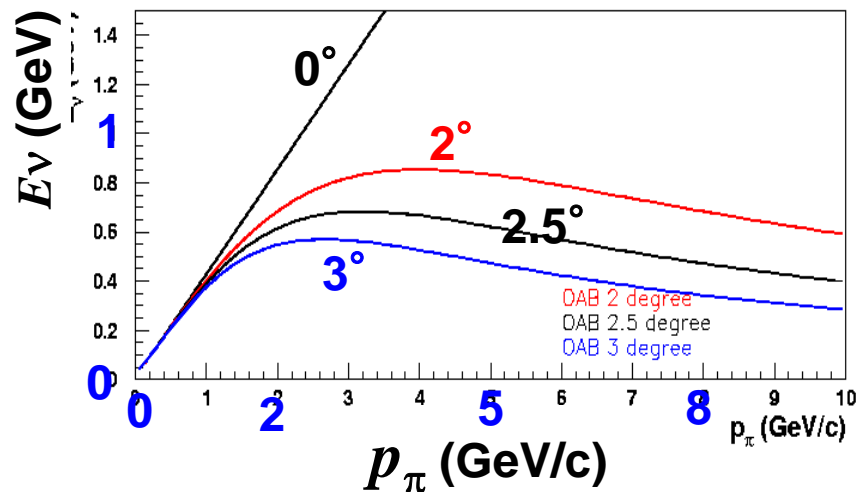
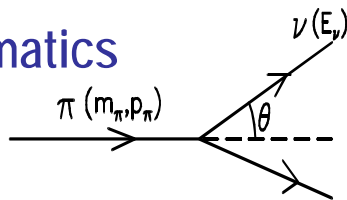

- ◆ Quasi Monochromatic Beam
- ◆ x 2~3 intense than NBB
- ◆ Tuned at oscillation maximum

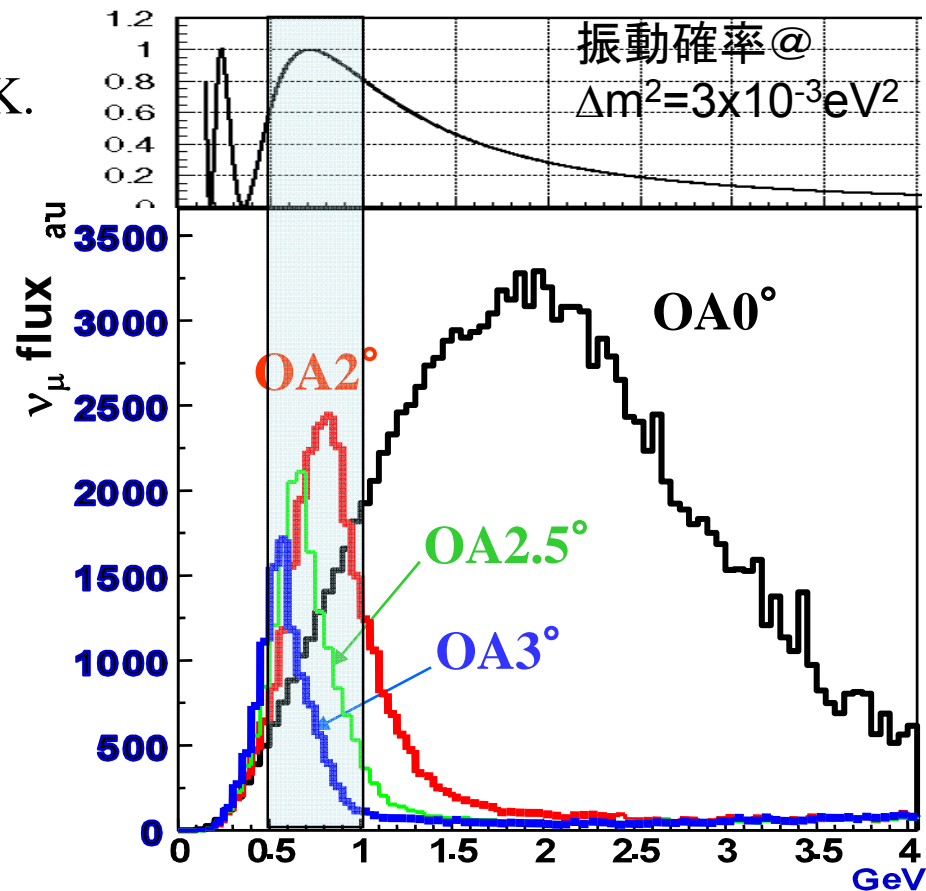

Statistics at SK

(OAB 2.5 deg, 1 yr, 22.5 kt)

~ 2200 ν_μ tot

~ 1600 ν_μ CC

ν_e ~0.4% at ν_μ peak

Summary of Status

	Conceptual Design	Engineering Design	Real Production	Installation
Proton Beam monitor				Feb.~
Superconducting magnets				Feb~
Cryogenics				Apr~
Normal Conducting magnets				
Vacuum system				
Target				Aug.~
Horn				Aug.~
Target Station				
Beam Window				Jul~
Decay Volume				
Beam Dump				Aug~
Muon monitor				08/09

- All components are in production phase
- Installations are starting as scheduled

Primary beam line

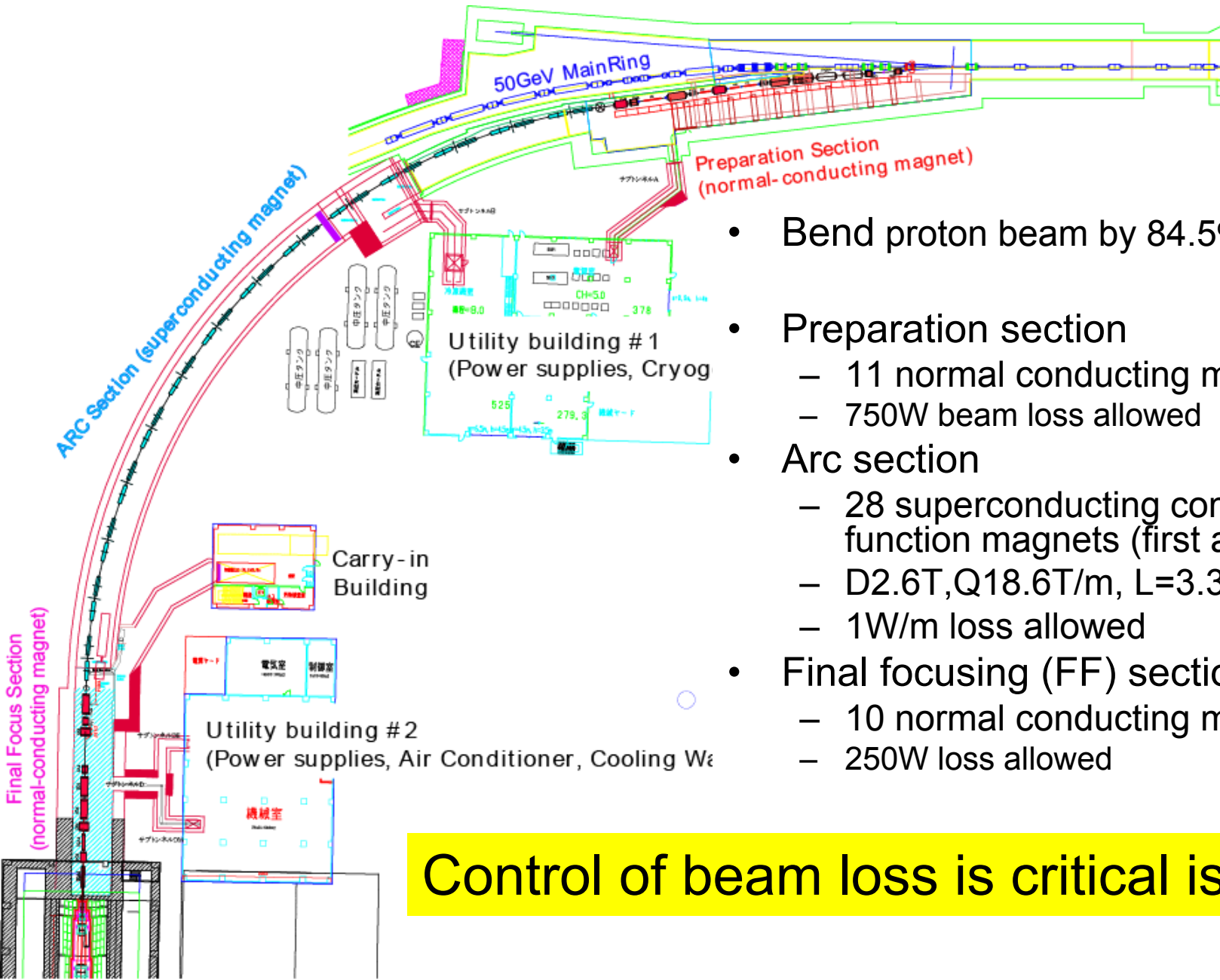

- Bend proton beam by 84.5°
- Preparation section
 - 11 normal conducting magnets
 - 750W beam loss allowed
- Arc section
 - 28 superconducting combined function magnets (first application)
 - D2.6T, Q18.6T/m, L=3.3m
 - 1W/m loss allowed
- Final focusing (FF) section
 - 10 normal conducting magnets
 - 250W loss allowed

Control of beam loss is critical issue

Tunnel for Primary Beam-line

Preparation Section

50GeV

Extraction area



Completed in Dec. 2006

Arc Section

2007 6 22

Final Focus Section

Primary line components (1)

Superconducting magnets

- 26 (/28) mags, 11 (/14) “doublets” completed
- 6 doublets already installed in the tunnel
- Up to 28 mags, 12 dblt's in FY2007 (by Mar.2008)
- 4 corrector mags are produced by BNL. 2 are delivered to KEK, 2 more being fabricated
- Magnet safety system (MSS) by Saclay
 - Hardware being constructed almost on time (Delivery to KEK in June)

Superconducting magnets (doublet) in Tunnel



Correctors



MSS



Primary line components (2)

Normal-conducting magnets

- **11 mags in prep.section installed and aligned.**
- Installation of FF magnets starts in March 2008.

Misc.

- Installation of vacuum components / beam plug started.
- Level meas. in progress to monitor ground sink.



Proton beam monitors

Position: 20 x ESMs

Profile: 19 x SSEM s

Intensity: 5x CTs

- **Being assembled**
- **Installation started in prep sect**

Loss: 50 x Ionization chambers

- **Twenty monitors are purchased in this FY**

OTR detector (provided by Canada)

- Provide all-time profile just in front of target
- **Mirrors, rad-hard camera delivered**
- Manufacturing, assembling in progress

Electronics

- FADC for CT/ESM being produced by US
- FADC for SSEM prepared by Korea

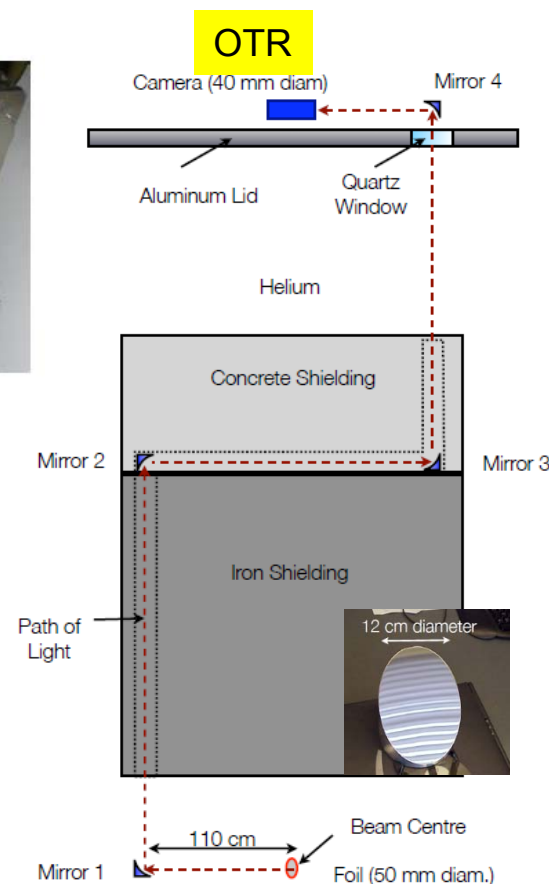
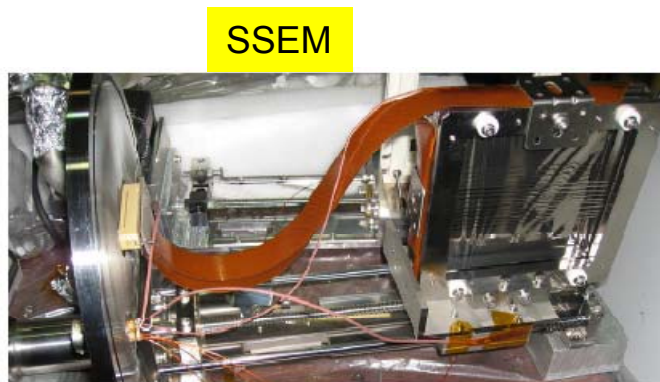
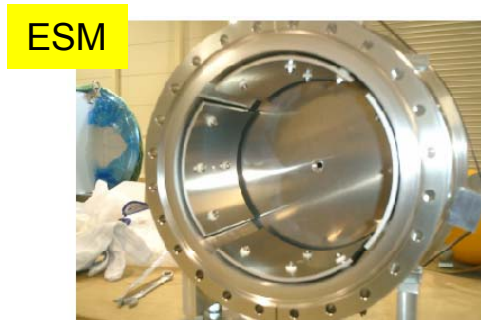

Target Station

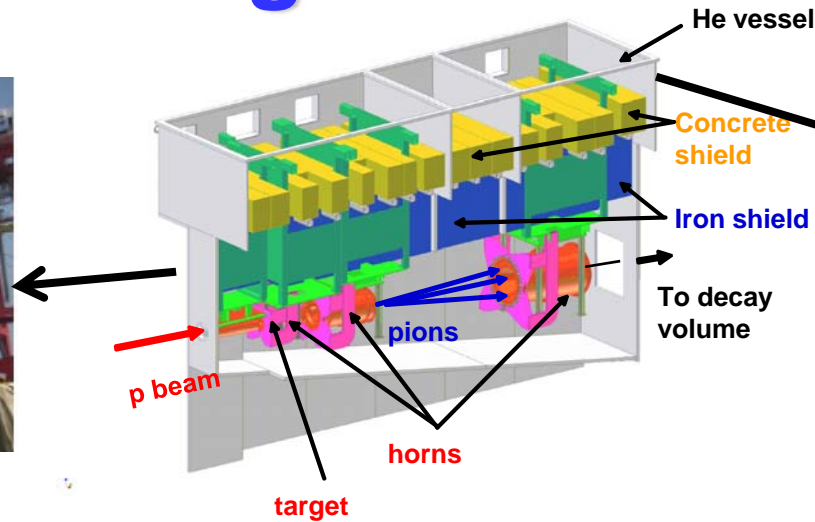

- Overcame water food problem during excavation in early 2007
- Installation of the helium vessel (~470ton, 1000m³) finished, passed vacuum test in Nov. 2007 **as scheduled**
- Construction of surface building starts soon and will finish in June 2008.

Target

CFX

- Graphite core
26mm(D)x900mm(L)
- Forced flow Helium gas cooling in
Ti-alloy container
- Design done by KEK/RAL
- **Day-1 target was delivered.**
- **Full-spec He-flow was achieved.**

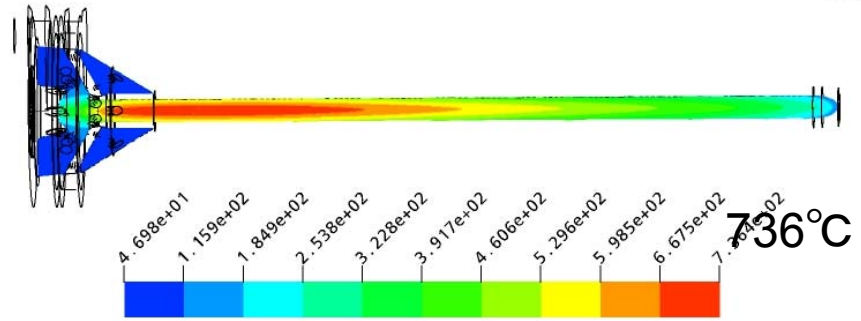

$\Delta T \sim 200K \sim 7MPa$ (Tensile 27MPa)

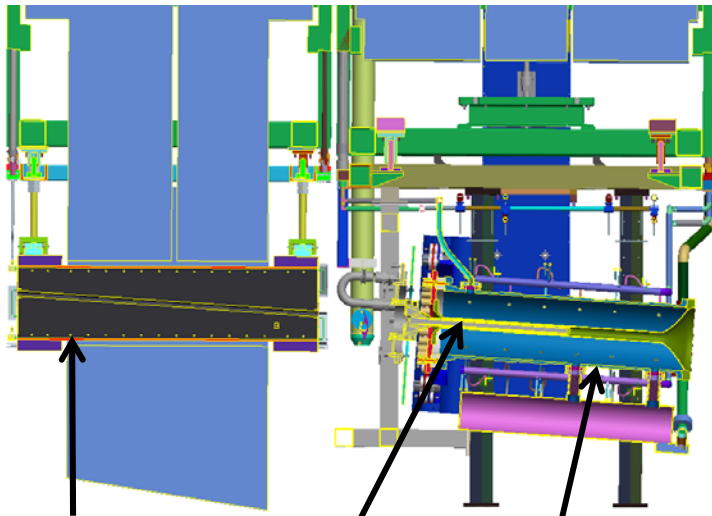

Baffle (RAL)

Target

1st horn

Electromagnetic horns

- 3 horn system with 320kA pulsed current operation, water cooled.
- Long term test at 320kA with 1st horn prototype and 3rd horn finished
 - Minor problems are indentified and being fixed before day-1.
- The 1st Horn for day-1 is under production, will be delivered in Mar.
- The 2nd Horn is under production in US, will be delivered in May.

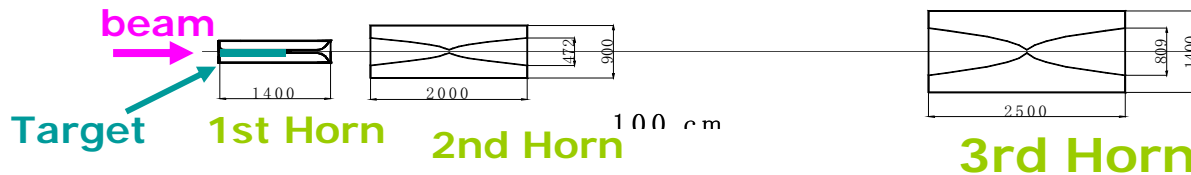

Long-term Operation Test at 320kA

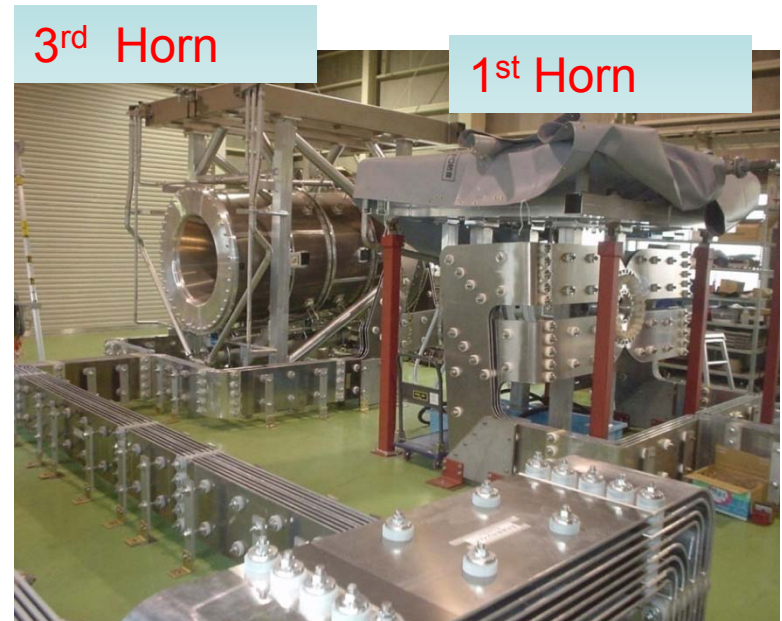
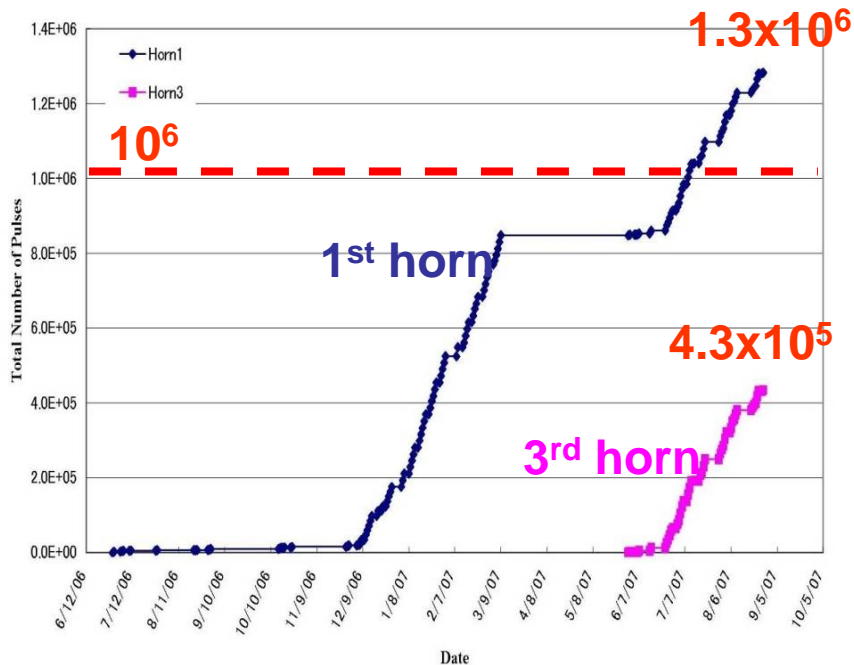

Full system setup Test of Horn and Demonstration of its Remote Maintenance Scenario at Fuji, KEK

In preparation now.

The 320 kA test operation soon.

Necessary improvements are identified and being solved.

Support Module

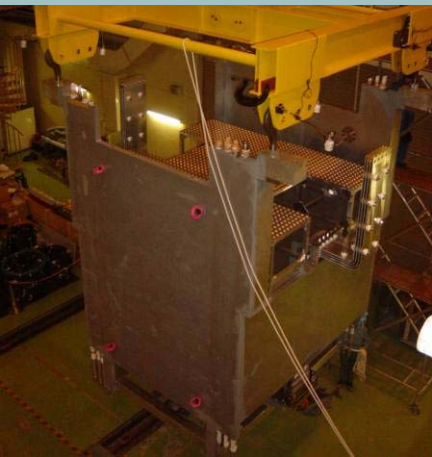

Full Setup

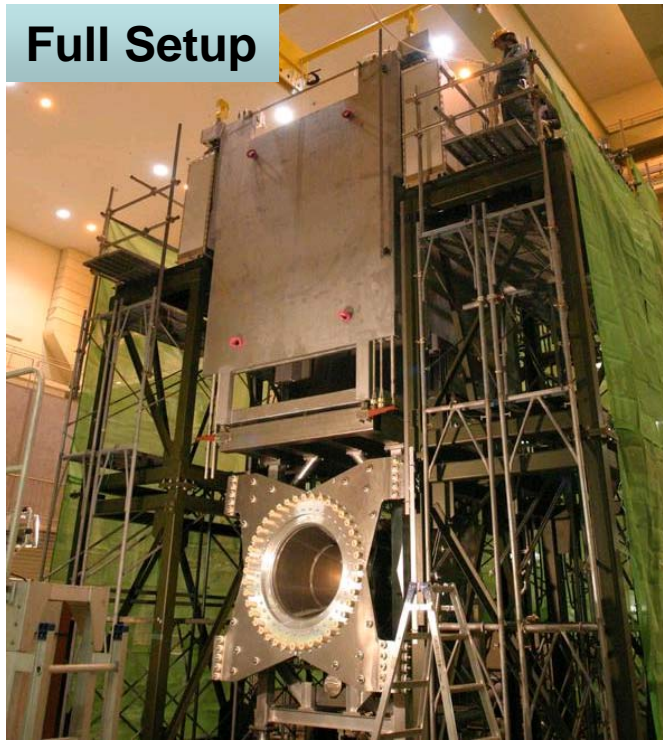

Hung by remote sling tool



3rd Horn

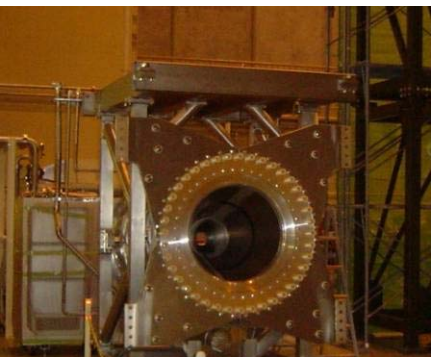

Target Station (2)



Downstream dome

Upstream dome



Downstream plate

Upstream plate

Pillow seal flange for window

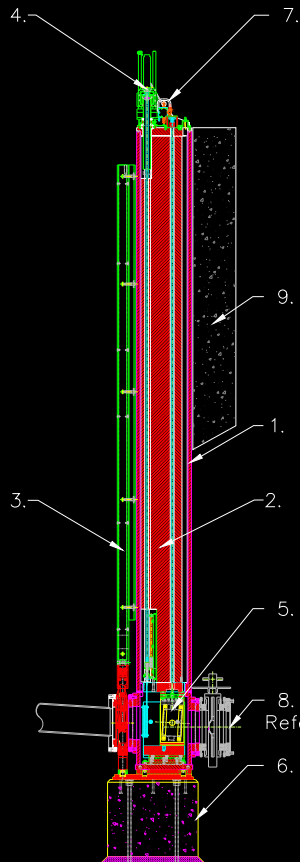

Beam window @RAL

Monitor chamber @TRIUMF

Mockup monitor Pillow seal flange for monitor chamber

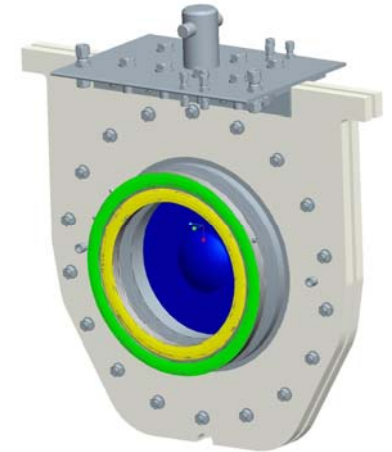
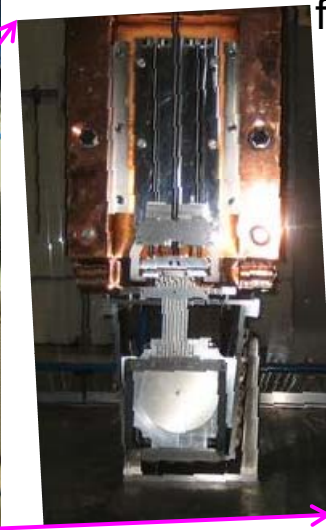
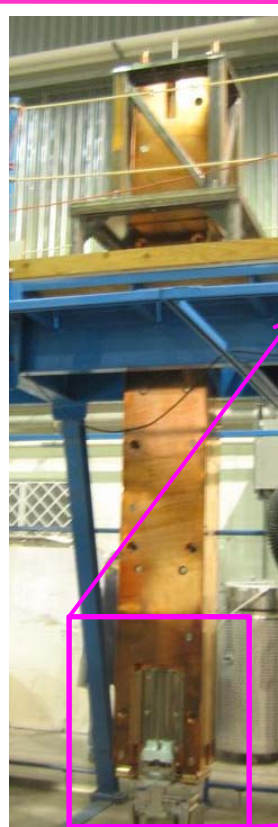

Beam window and monitor chamber are under assembly at RAL/TRIUMF and will be installed into TS from July 2008.

Decay Volume

- Upstream part (20cm^t Iron) was installed & tested in Nov 2007.
- Anchor frame for BD core was embedded in concrete in Feb. 2008.
- Civil construction of downstream part will be finished by Aug.
- Construction of He vessel:
for DV: just started, for BD: will start in Aug. 2008.

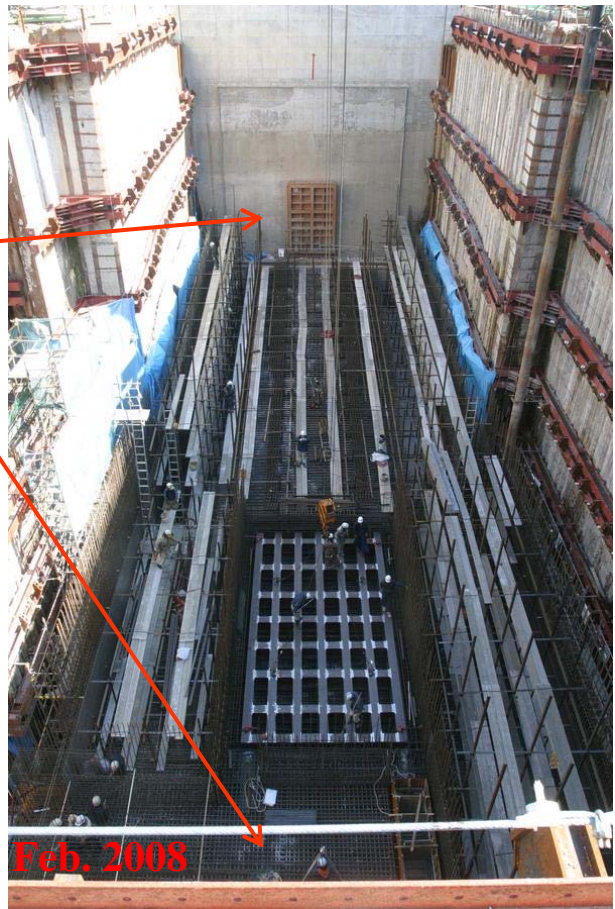
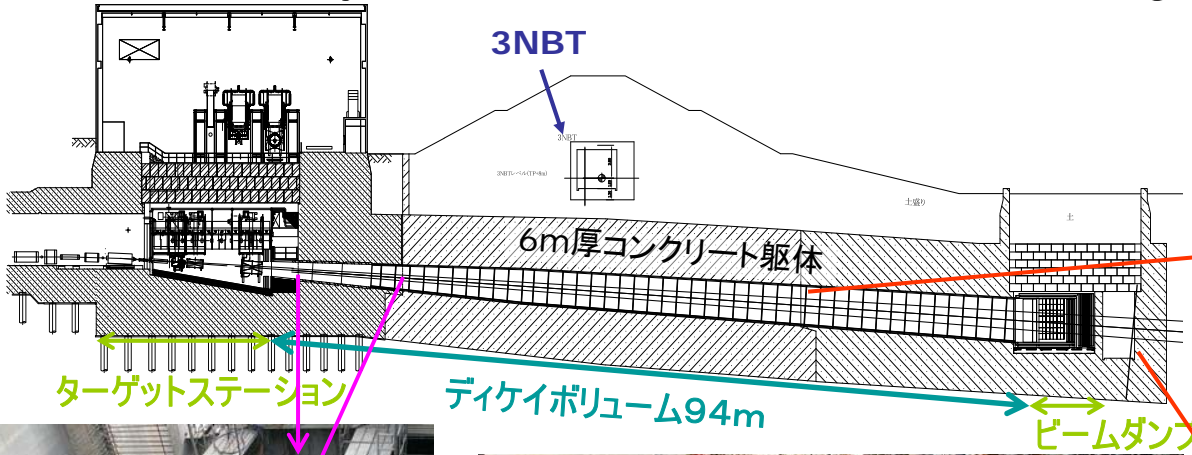

Upstream part

Anchor frame for BD core

Downstream part

Beam Dump

- 98 graphite blocks cooled by Al cooling blocks
- Graphite block: 72 delivered out of 98
- Al-cooling module: 4 delivered out of 14
- Two modules were assembled at LINAC building,
- Core will be Installed into He vessel in Oct/Nov 2008.

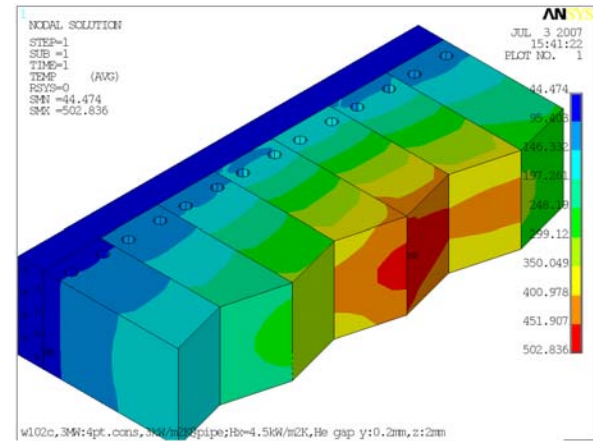

500°C with 3MW
[Assuming phase-I target]

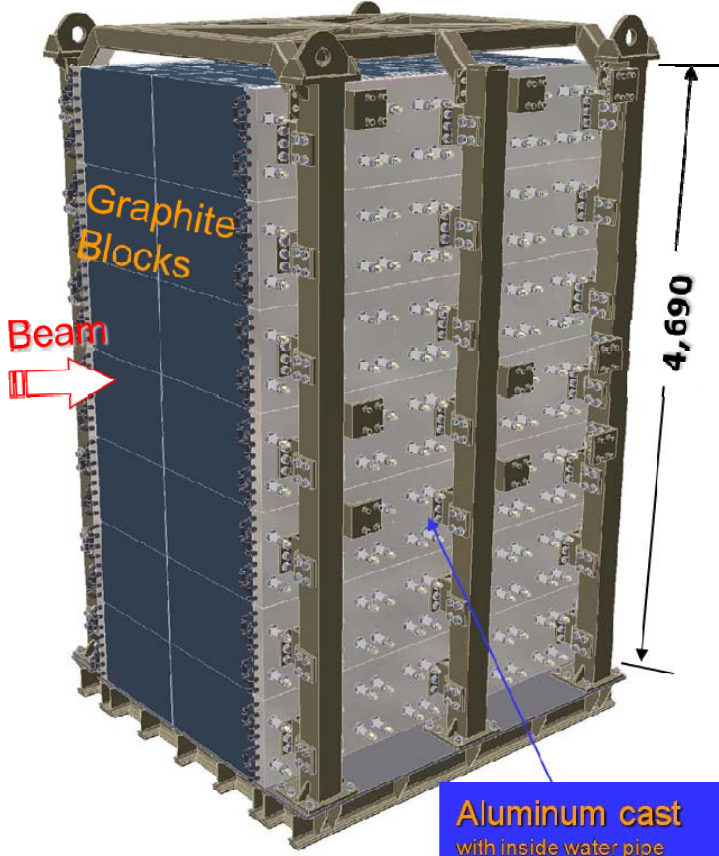

Muon Monitor

- Spill-by-spill monitor for the muon profile center (= beam direction)
- Long term test of prototype at FNAL/NuMI beamline (FNAL-T968 test exp.)
- Installation in fall-winter 2008



T2K prototype detectors installed behind NuMI/MINOS MUMON

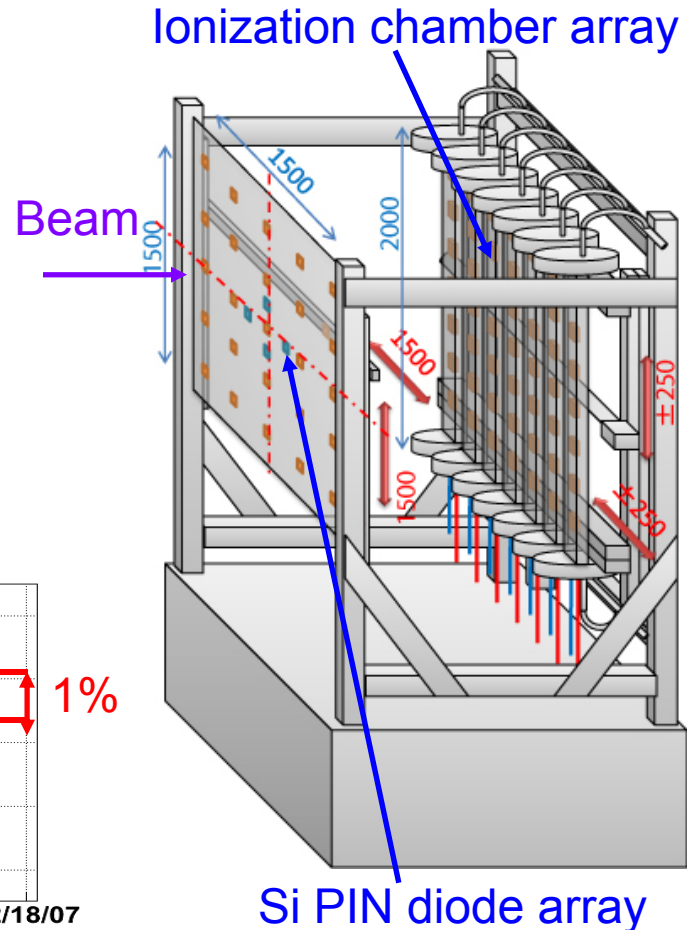
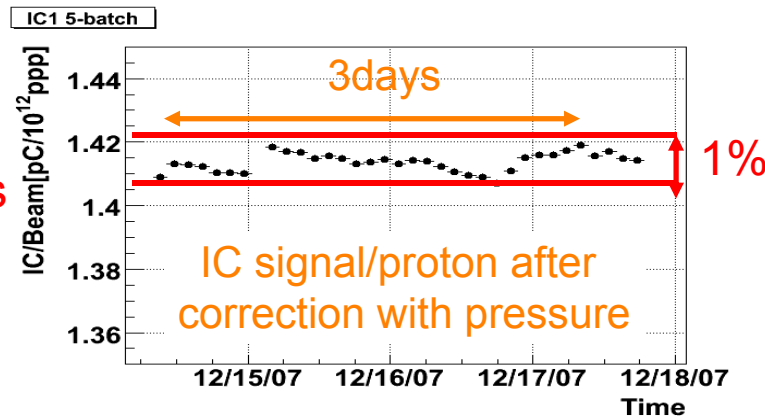
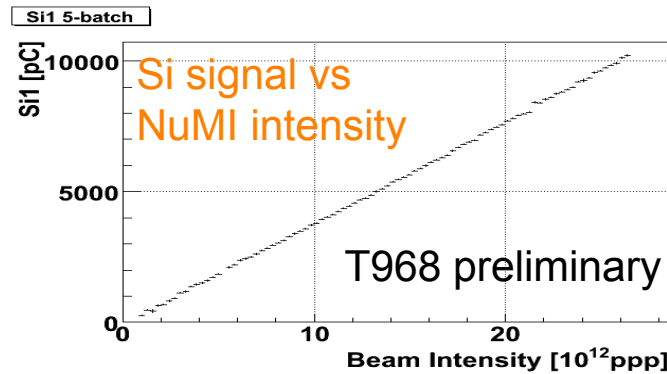

Beam-line control system

- Fast spill synchronized DAQ
 - MAIDAS based newly developed intermediate event-builder for many readout CPUs (~50nodes)
 - Achieved requirement on data transfer latency (<500msec)

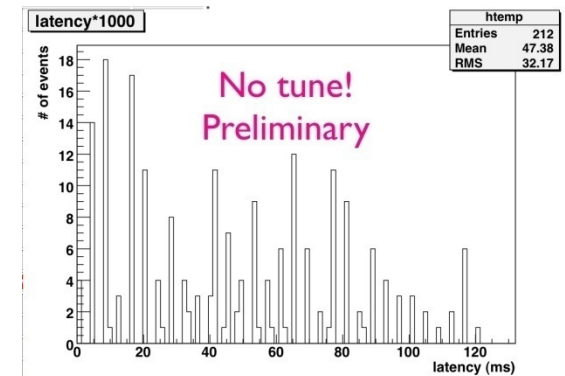
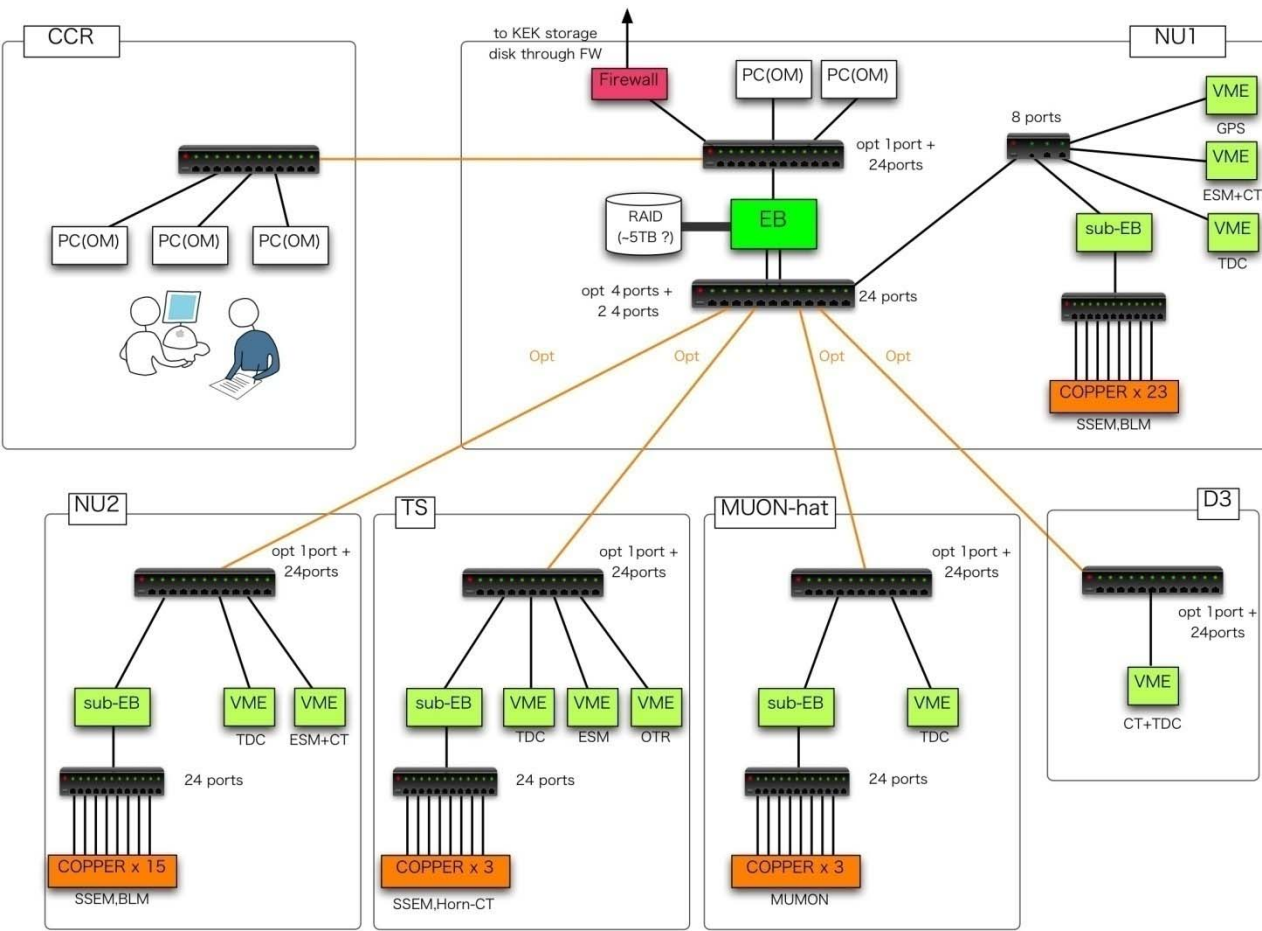

**Result of latency R&D :
achieved requirement
(<500msec)**

Near Neutrino Detectors @ 280m

On-axis neutrino monitor

- Monitor
 - Profile
 - Direction
 - Intensity (& Energy)
- Iron-Scintillator sandwich detector
 - 1mx1mx10cm Iron
 - 1.25cm thick extruded Scinti.
 - New Photo-Sensor (MPPC/SiPM)

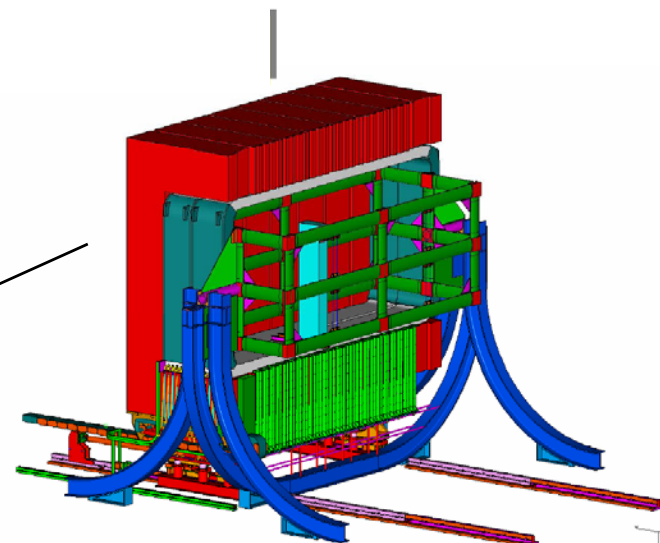
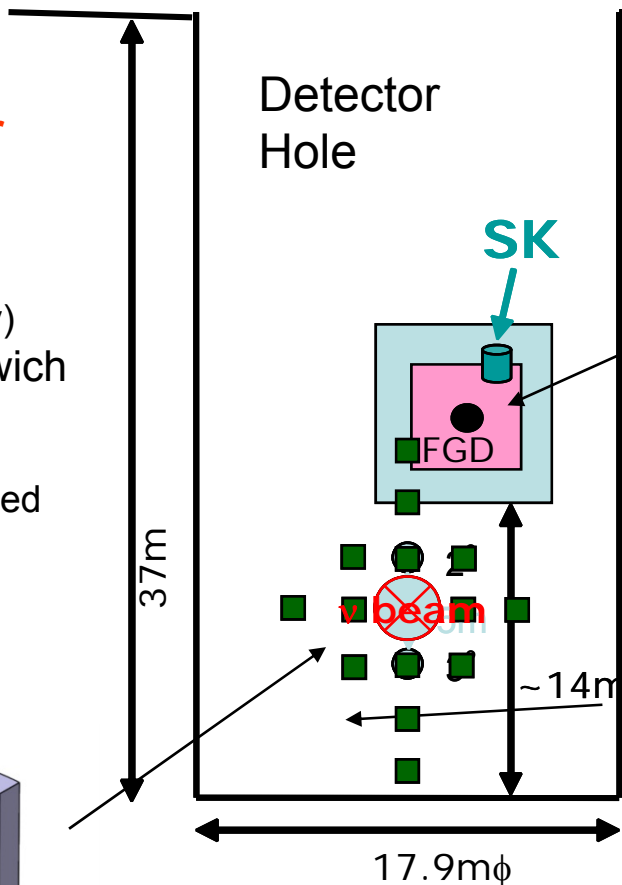

Conceptual design optimization versus PIT

Off-axis detector

- Measurement of ν flux and σ in the SK direction.
- Detector components.
 - UA1 magnet (0.2T)
 - TPC
 - Fine-Grained Scintillator detector (FGD)
 - Lead/Scintillator tracking detector for π^0
 - Electromagnetic Calorimeter
 - Muon Range Detector in mag
- Key technologies
 - Photo-sensor, Micromegas

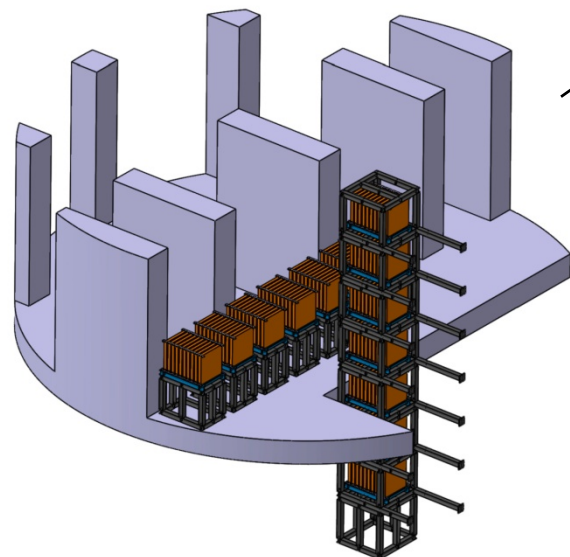

280m detector hole construction



- 17.5m- ϕ x 33.5m deep hole excavation finished in Jan 2009
- Underground floors being constructed.
- UA1 magnet installation Apr-Jun, 2008
- **Construction is on schedule**



Hadron production measurements at CERN-SPS NA61 (SHINE) experiment

- Measure hadron (π/K) production from Graphite target
 - to predict
 - Near and far energy spectra (<2~3%)
 - Near to far spectrum extrapolation (<2~3%)
 - ν_e contami. (from K, μ) (<2~3%)
- **First data taking successfully finished in Oct., 2007 (1month)**
 - Beam: 30GeV proton
 - Thin target (2cm^t 4%int):~ 500k int.
 - Replica target (90cm, 80%int): ~180k int.
- Measurements in 2008 planned

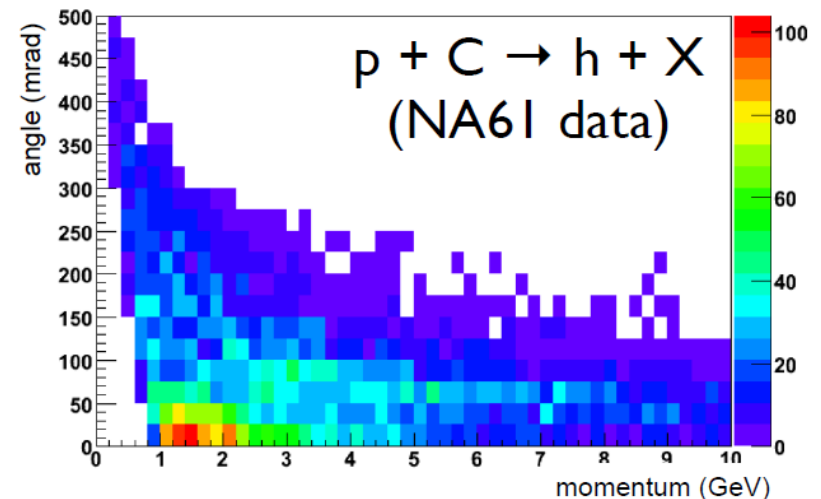
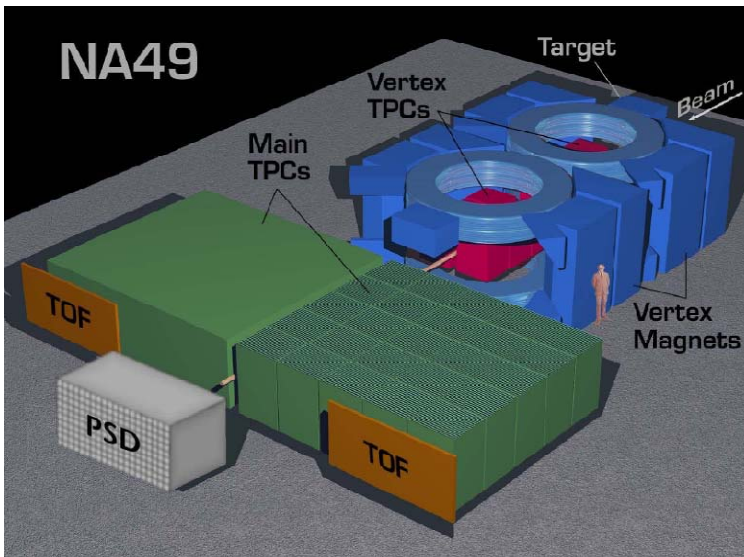
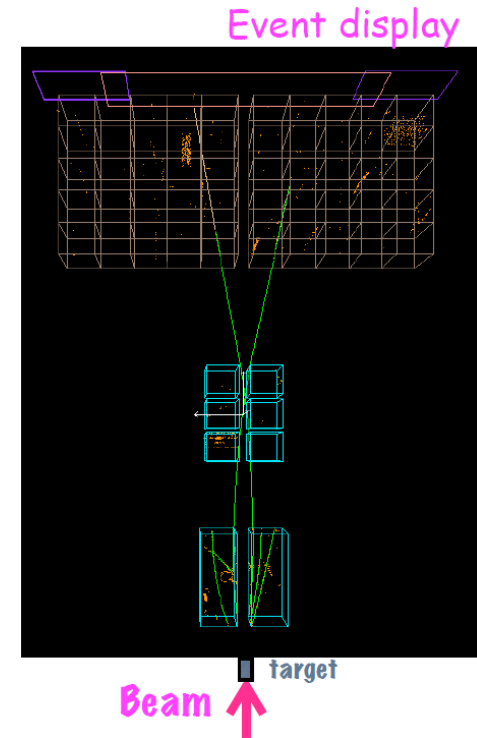

First look of data
(PID, acceptance not corrected)

Construction schedule



- Installation of almost all components in 2008
 - SC magnets from Feb, Target/Horn from July,
 - SC/Horn in-situ ope. test from 2009, Intrlock inspection Mar. 2009
- Beam will start in April 2009, 13month from now.

Summary

- **Many milestones achieved in 2007**
 - Huge Helium vessel of TS installed and passed vacuum test on schedule
 - Long term full-current test of 1st and 2nd horn done
 - Horn full-system support test. (Operation test soon)
 - Day-1 Target Delivered, full spec He flow test succeeded
 - NA61 experiment started
- **Beam line construction is on schedule**
- **Installation of most components in 2008**
 - SC mags inst. from Feb, Tgt/Horn from July, etc.
- **We can start beam in Apr. 2009**

Target

Helium-Cooled Graphite Target in the 1st Horn

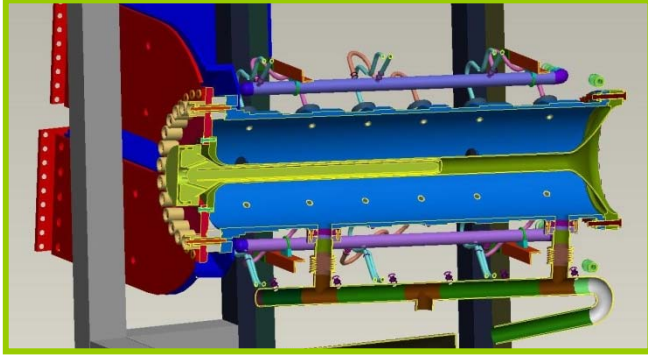

CFX

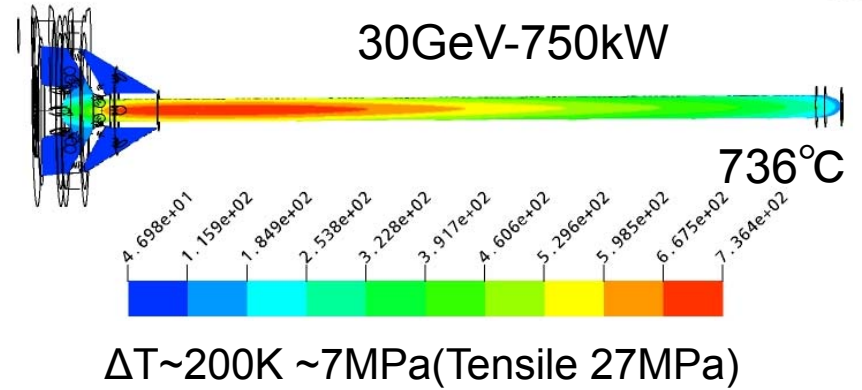
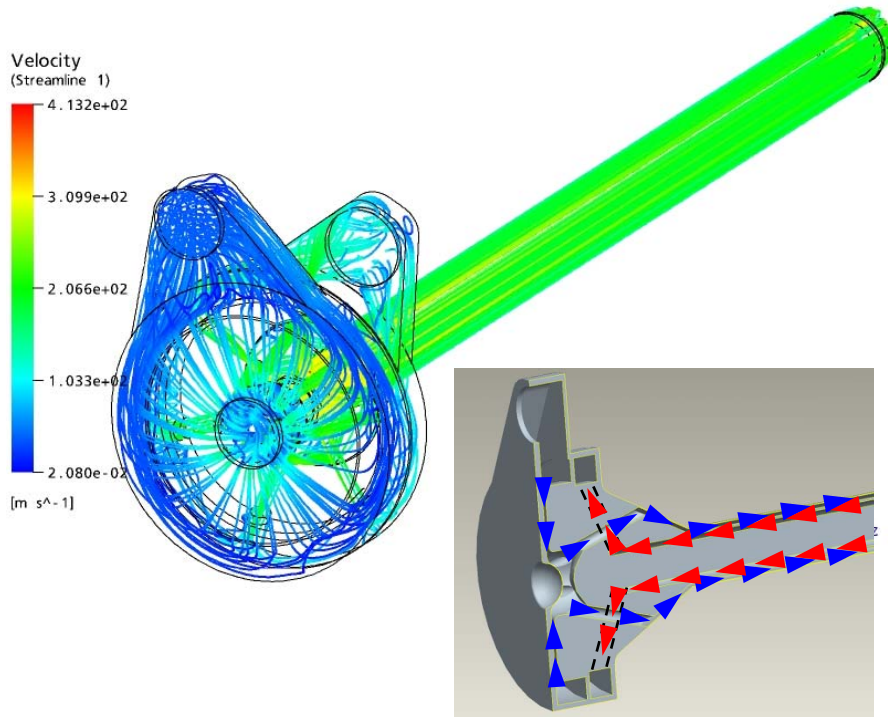

Beam Dump

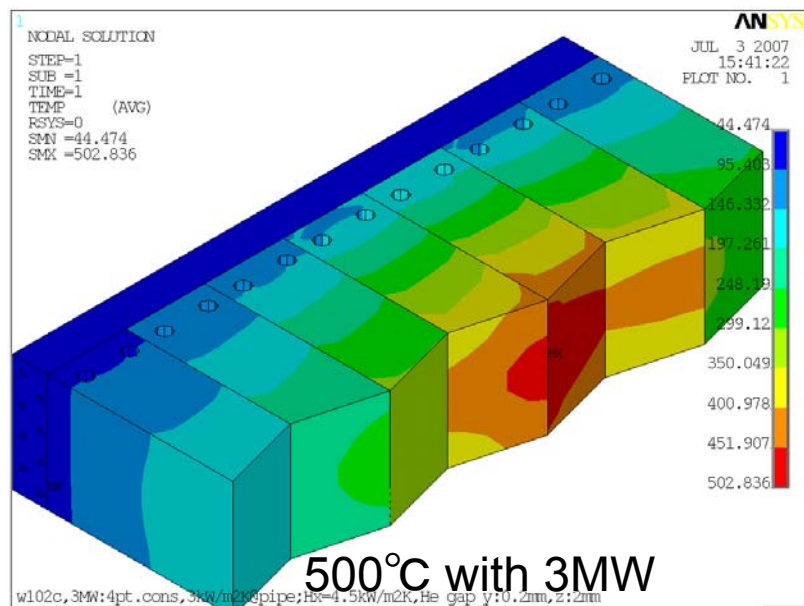
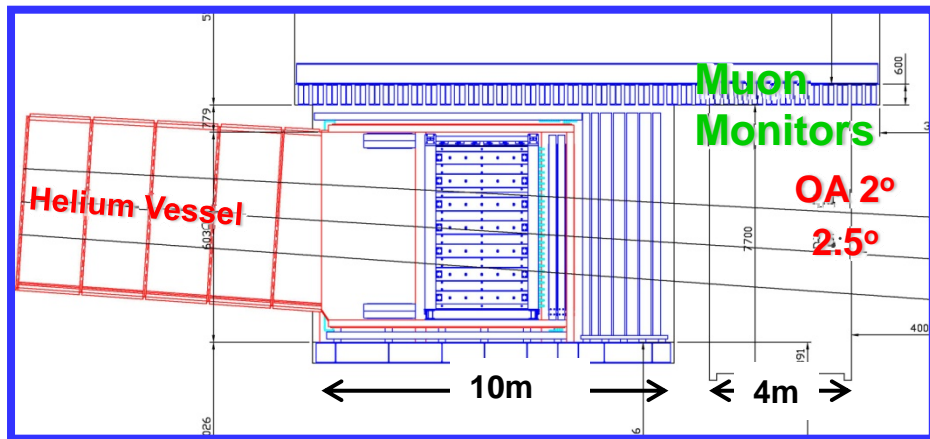

500°C with 3MW
[Assuming phase-I target]

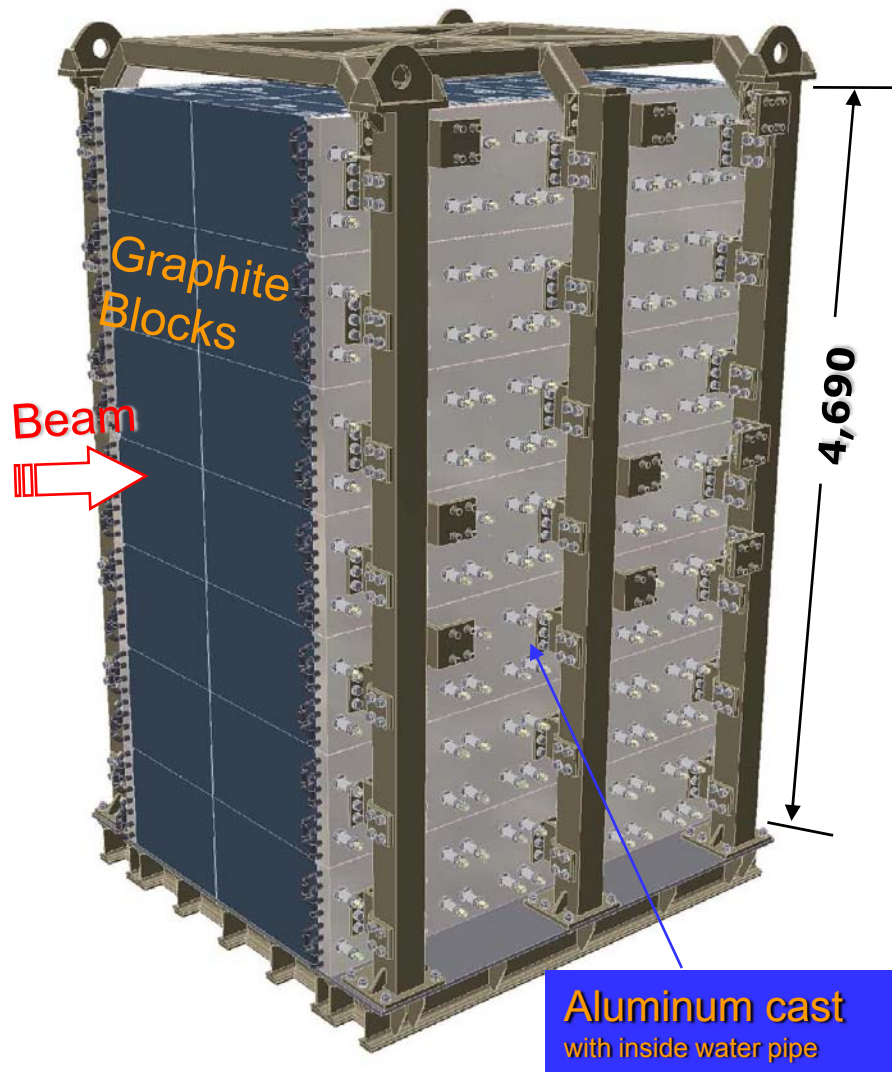

Common decay pipe for SK/HK covering 2~3 deg OA angle

Candidate site for HK

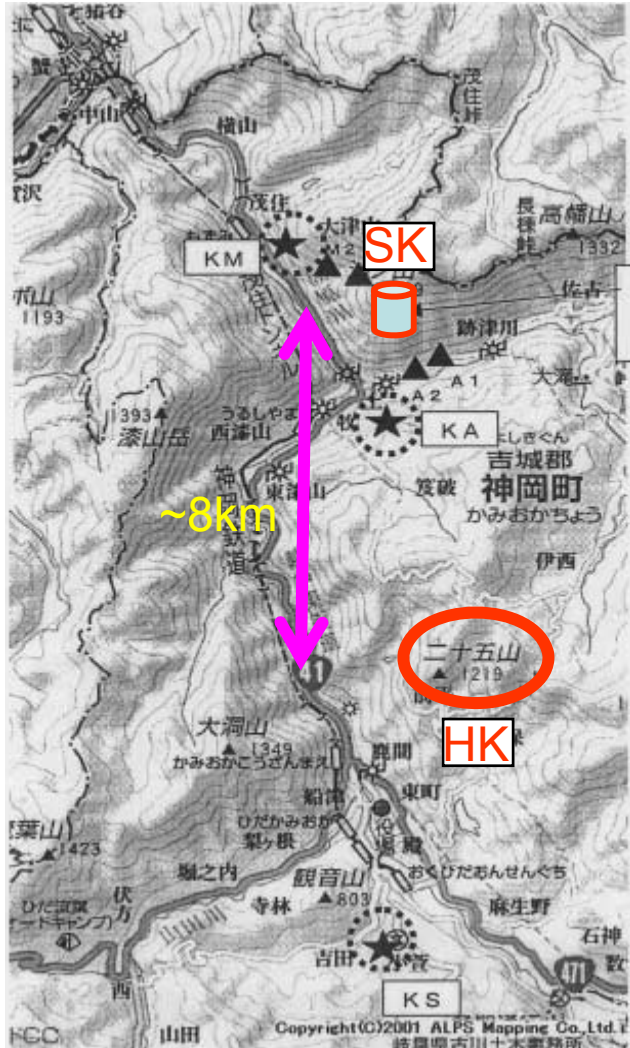

Beam eye

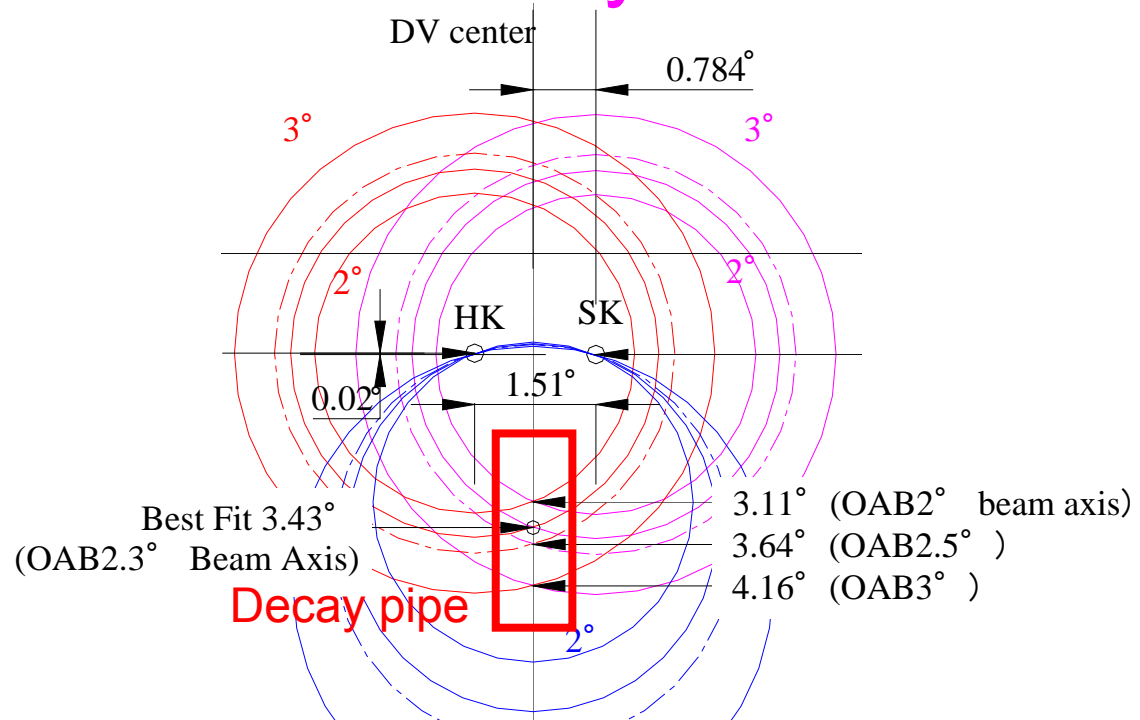

表 3.1: E_ν at the oscillation maximum for the baseline length of 295km and corresponding off-axis angle.

Δm^2	2.04	2.18	2.75	3.17	3.28
$[10^{-3}eV^2]$	(90% A.R.)	(80% A.R.)	(best fit)	(80% A.R.)	(90% A.R.)
$E_\nu [GeV]$	0.487	0.520	0.656	0.756	0.782
OA angle[deg.]	3.1	3.0	2.4	2.1	2.0

Cover this region